

Atlas Digital Amplifier User Manual

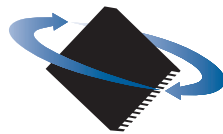

**PERFORMANCE
MOTION DEVICES**

Performance Motion Devices, Inc.
1 Technology Park Drive
Westford, MA 01886



NOTICE

This document contains proprietary and confidential information of Performance Motion Devices, Inc., and is protected by federal copyright law. The contents of this document may not be disclosed to third parties, translated, copied, or duplicated in any form, in whole or in part, without the express written permission of PMD.

The information contained in this document is subject to change without notice. No part of this document may be reproduced or transmitted in any form, by any means, electronic or mechanical, for any purpose, without the express written permission of PMD.

Copyright 1998–2020 by Performance Motion Devices, Inc.

Juno, Atlas, Magellan, ION, Prodigy, Pro-Motion, C-Motion and VB-Motion are trademarks of Performance Motion Devices, Inc.

Warranty

Performance Motion Devices, Inc. warrants that its products shall substantially comply with the specifications applicable at the time of sale, provided that this warranty does not extend to any use of any Performance Motion Devices, Inc. product in an Unauthorized Application (as defined below). Except as specifically provided in this paragraph, each Performance Motion Devices, Inc. product is provided “as is” and without warranty of any type, including without limitation implied warranties of merchantability and fitness for any particular purpose.

Performance Motion Devices, Inc. reserves the right to modify its products, and to discontinue any product or service, without notice and advises customers to obtain the latest version of relevant information (including without limitation product specifications) before placing orders to verify the performance capabilities of the products being purchased. All products are sold subject to the terms and conditions of sale supplied at the time of order acknowledgment, including those pertaining to warranty, patent infringement and limitation of liability.

Unauthorized Applications

Performance Motion Devices, Inc. products are not designed, approved or warranted for use in any application where failure of the Performance Motion Devices, Inc. product could result in death, personal injury or significant property or environmental damage (each, an “Unauthorized Application”). By way of example and not limitation, a life support system, an aircraft control system and a motor vehicle control system would all be considered “Unauthorized Applications” and use of a Performance Motion Devices, Inc. product in such a system would not be warranted or approved by Performance Motion Devices, Inc.

By using any Performance Motion Devices, Inc. product in connection with an Unauthorized Application, the customer agrees to defend, indemnify and hold harmless Performance Motion Devices, Inc., its officers, directors, employees and agents, from and against any and all claims, losses, liabilities, damages, costs and expenses, including without limitation reasonable attorneys’ fees, (collectively, “Damages”) arising out of or relating to such use, including without limitation any Damages arising out of the failure of the Performance Motion Devices, Inc. product to conform to specifications.

In order to minimize risks associated with the customer’s applications, adequate design and operating safeguards must be provided by the customer to minimize inherent procedural hazards.

Disclaimer

Performance Motion Devices, Inc. assumes no liability for applications assistance or customer product design. Performance Motion Devices, Inc. does not warrant or represent that any license, either express or implied, is granted under any patent right, copyright, mask work right, or other intellectual property right of Performance Motion Devices, Inc. covering or relating to any combination, machine, or process in which such products or services might be or are used. Performance Motion Devices, Inc.’s publication of information regarding any third party’s products or services does not constitute Performance Motion Devices, Inc.’s approval, warranty or endorsement thereof.

Patents

Performance Motion Devices, Inc. may have patents or pending patent applications, trademarks, copyrights, or other intellectual property rights that relate to the presented subject matter. The furnishing of documents and other materials and information does not provide any license, express or implied, by estoppel or otherwise, to any such patents, trademarks, copyrights, or other intellectual property rights.

Patents and/or pending patent applications of Performance Motion Devices, Inc. are listed at <https://www.pmdcorp.com/company/patents>.

Related Documents

Atlas Digital Amplifier Complete Technical Reference

Complete technical and mechanical description of the Atlas Digital Amplifier with detailed theory of operations.

Magellan Motion Control IC User Guide

Complete description of the Magellan Motion Control IC features and functions with detailed theory of its operation.

MC58113 Developer Kit User Manual

How to install, configure, and operate the MC58113 Family IC developer kits.

Magellan Motion Control IC Developer Kit User Manual

How to install, configure, and operate the DK58000 Magellan Motion Control IC Developer Kit.

Table of Contents

1. Introduction	9
1.1 Atlas Digital Amplifier Overview	9
1.2 Typical Applications	10
1.3 Features and Functions	12
1.4 Atlas Developer Kits	14
2. Functional Characteristics	17
2.1 Operational Specifications	17
2.2 Physical Dimensions	18
2.3 Mechanical Mounting Options	20
3. Electrical Specifications	25
3.1 Drive Ratings	25
3.2 Absolute Maximum Ratings	26
3.3 Environmental Ratings	27
3.4 Safety and Compliance	27
3.5 DC Characteristics	27
3.6 AC Characteristics	29
3.7 Pin Descriptions and Pinouts	29
3.8 Signal Interfacing	34
3.9 Connection Overview	35
3.10 Heat Sink Grounding	38
3.11 Atlas Conversion Factors	38
4. Operation	41
4.1 Functional Overview	41
4.2 Internal Block Diagram	42
4.3 Commutation	43
4.4 Current Loop	44
4.5 Power Stage	45
4.6 Status Registers	45
4.7 Safety Processing Functions	46
4.8 Step Motor Control	49
4.9 User Memory Space & Buffers	51
4.10 Trace Capture	51
4.11 Power-Up & Non-Volatile Initialization Storage	52
4.12 SPI Communications Overview	52
A. Atlas Developer Kits	55
A.1 Overview	55
A.2 Developer Kit P/Ns	56
A.3 Installation and Getting Started	56
A.4 Atlas DK Board Reference Information	62
A.5 L-Bracket	68
B. Application Notes	71
B.1 Brushless DC Atlas With Single-Axis MC58113 Motion Control IC	71
B.2 DC Brush & Step Motor Atlas With Multi-Axis Magellan	74
B.3 Step Motor Atlas Operating In Pulse & Direction Mode	76
B.4 DC Brush Atlas With PIC Microcontroller	78
B.5 Step Motor Atlas With ARM Microcontroller	80
B.6 Atlas Interfacing Via A Daughter Card	82
B.7 Multi-Motor Atlas With Single-Axis MC58113 Motion Control IC	86

This page intentionally left blank.

List of Figures

1-1	Single Axis Magellan With Atlas Amplifier	10
1-2	Multi Axis Magellan With Atlas Amplifiers	11
1-3	Direct Host Microprocessor With Atlas Amplifiers	11
1-4	Direct Host Microprocessor With Atlas Amplifiers	12
1-5	Atlas Force Control	12
1-6	Developer Kit Components	14
2-1	Vertical Unit - Ultra Compact Package	18
2-2	Horizontal Unit - Ultra Compact Package	18
2-3	Vertical Unit - Compact Package	19
2-4	Horizontal Unit - Compact Package	19
2-5	Horizontal & Vertical Unit Mounting Options	21
2-6	Recommended Atlas Unit Thermal Transfer Material Dimensions	23
2-7	Atlas Torque Specifications	24
3-1	Timing Diagrams	29
3-2	Atlas Pinouts - Ultra Compact, Vertical	30
3-3	Atlas Pinouts - Ultra Compact, Horizontal	30
3-4	Atlas Pinouts - Compact, Vertical	31
3-5	Atlas Pinouts - Compact, Horizontal	31
3-6	Signal Interfacing ~Enable	34
3-7	Signal Interfacing FaultOut	34
3-8	Brushless DC Connections	35
3-9	DC Brush Connections	36
3-10	Step Motor Pulse and Direction Mode Connections	37
3-11	Step Motor SPI Communication Connections	38
4-1	High Level System Diagram	41
4-2	Internal Block Diagram	42
4-3	Commutation Control Sequence	43
4-4	Current Loop Control Flow	44
4-5	Current Foldback Processing Example	49
4-6	Pulse and Direction Signal Input Mode Control Flow	50
4-7	User Memory Space and Buffers	51
4-8	Example Motion Trace Capture	51
4-9	SPI Communications Protocol Overview	53
4-10	Sending a Voltage or Torque Output Value	53
A-1	Developer Kit Components (four-axis version shown)	55
A-2	Thermal Transfer Material Attachment	57
A-3	Vertical Atlas Installation into DK Board	57
A-4	Attaching Atlas Units to Vertical Plate	58
A-5	Horizontal Atlas Units and Heat Sink	59
A-6	Horizontal Atlas Installation into DK Board	59
A-7	Connecting DB9 Cable to DK Board	60
A-8	Component Placement of Vertical and Horizontal DK DK Boards (four-axis version shown)	62
A-9	Vertical Unit Pinouts	65
A-10	Horizontal Unit Pinouts	66
A-11	Mounting Atlas to L-bracket Plates (four-axis, vertical version shown)	68
A-12	Top and Front Views of Four-Axis Horizontal Atlas DK L-bracket Vertical Plate	69
A-13	Top and Front Views of One-Axis Horizontal Atlas DK L-bracket Vertical Plate	69
B-1	Brushless DC Atlas With Single-Axis Magellan	73
B-2	DC Brush & Step Motor Atlas With Multi-Axis Magellan	75

B-3	Step Motor Atlas Operating In Pulse & Direction Mode	77
B-4	DC Brush Atlas With PIC Microcontroller	79
B-5	Step Motor Atlas With ARM Microcontroller	81
B-6	Atlas Interfacing Via A Daughter Card #1	84
B-7	Atlas Interfacing Via A Daughter Card #2	85
B-8	Multi-motor Atlas With MC58113 Motion Control IC	87

1. Introduction

In This Chapter

- ▶ Atlas Digital Amplifier Overview
- ▶ Typical Applications
- ▶ Features and Functions
- ▶ Atlas Developer's Kits

1.1 Atlas Digital Amplifier Overview

Atlas Digital Amplifiers are single-axis amplifiers that provide high performance torque control of brushless DC, step motor, and DC Brush motors. They accept digital torque commands from an external source and are used directly for motor torque control applications, or in conjunction with higher level controllers for velocity or positioning applications. Their very compact size and range of power output levels make them an ideal solution for single-card machine controllers that require high performance in a small envelope.

Atlas digital amplifiers provide many advanced control features including user-programmable gain parameters, performance trace, field oriented control, and I²t current management. Atlas amplifiers are powered from a single supply voltage, and provide automatic protection from overcurrent, undervoltage, overvoltage, overtemperature, and short circuit faults.

The Atlas digital amplifier family has been designed to work seamlessly with PMD's Magellan family of motion control ICs. Alternatively, they can be used with dedicated FPGAs, digital signal processors, or general purpose microprocessors. Communication to/from Atlas amplifiers is via SPI (Serial Peripheral Interface) using a simple, packet-oriented protocol. For step motors, in addition to the SPI format a dedicated pulse & direction input mode is provided.

Atlas amplifiers are packaged in plastic and metal solderable modules and are available in an ultra compact package size with a total footprint of 1.4 inch² (9.0 cm²) and a compact package size with a footprint of 2.6 inch² (16.8 cm²). They come in three power levels; 75 watts, 250 watts, and 500+ watts and utilize standard through-hole pins for all electrical connections.

Atlas amplifiers are provided in both vertical and horizontal mounting configurations and have integral attachment tabs to allow for a variety of mechanical mounting and heat sink options. The following table shows the available configurations of the Atlas Digital Amplifiers:

P/N	Power Level (continuous)	Voltage	Size	Mounting Style	Motor Type
Step Motor					
MD241048/02VB	Low (75W)	12-48V	Ultra compact	Vertical	Step Motor
MD241048/02HB	Low (75W)	12-48V	Ultra compact	Horizontal	Step Motor
MD241048/05VB	Medium (250W)	12-48V	Ultra compact	Vertical	Step Motor
MD241048/05HB	Medium (250W)	12-48V	Ultra compact	Horizontal	Step Motor
MD141056/25VB	High (500+W)	12-56V	Compact	Vertical	Step Motor
MD141056/25HB	High (500+W)	12-56V	Compact	Horizontal	Step Motor

Brushless DC						
MD231048/02VB	Low (75W)	12-48V	Ultra compact	Vertical	Brushless DC	
MD231048/02HB	Low (75W)	12-48V	Ultra compact	Horizontal	Brushless DC	
MD231048/05VB	Medium (250W)	12-48V	Ultra compact	Vertical	Brushless DC	
MD231048/05HB	Medium (250W)	12-48V	Ultra compact	Horizontal	Brushless DC	
MD131056/25VB	High (500+W)	12-56V	Compact	Vertical	Brushless DC	
MD131056/25HB	High (500+W)	12-56V	Compact	Horizontal	Brushless DC	
DC Brush						
MD211048/02VB	Low (75W)	12-48V	Ultra compact	Vertical	DC Brush	
MD211048/02HB	Low (75W)	12-48V	Ultra compact	Horizontal	DC Brush	
MD211048/05VB	Medium (250W)	12-48V	Ultra compact	Vertical	DC Brush	
MD211048/05HB	Medium (250W)	12-48V	Ultra compact	Horizontal	DC Brush	
MD111056/25VB	High (500+W)	12-56V	Compact	Vertical	DC Brush	
MD111056/25HB	High (500+W)	12-56V	Compact	Horizontal	DC Brush	
Multi-Motor						
MD281048/02VB	Low (75W)	12-48V	Ultra compact	Vertical	Multi-motor*	
MD281048/02HB	Low (75W)	12-48V	Ultra compact	Horizontal	Multi-motor*	
MD281048/05VB	Medium (250W)	12-48V	Ultra compact	Vertical	Multi-motor*	
MD281048/05HB	Medium (250W)	12-48V	Ultra compact	Horizontal	Multi-motor*	
MD181056/25VB	High (500+W)	12-56V	Compact	Vertical	Multi-motor*	
MD181056/25HB	High (500+W)	12-56V	Compact	Horizontal	Multi-motor*	

*Multi-motor motor type allows the Atlas to be configured by the user to drive either Step Motor, Brushless DC, or DC Brush motor type.

This manual provides a description of the electrical and mechanical specifications for the Atlas Digital Amplifiers, along with a summary of its operational features. For complete documentation on all aspects of the Atlas Digital Amplifier including a programmers command reference refer to *Atlas Digital Amplifier Complete Technical Reference*. For more information on the Magellan Motion Control IC consult the *Magellan Motion Control IC User Guide*.

1.2 Typical Applications

The following section provides overview diagrams of typical applications utilizing the Atlas amplifier products.

1.2.1 Single Axis Positioning Motion Controller

The diagram below shows a PMD MC58113 Motion Control IC sending torque commands to an Atlas Amplifier to provide positioning control of a brushless DC, DC Brush, or Step Motor.

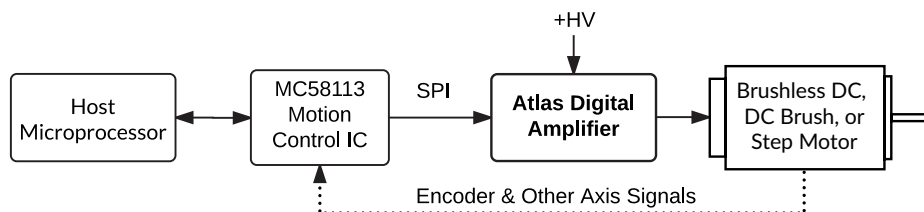

Figure 1-1:
Single Axis
Magellan With
Atlas Amplifier

1.2.2 Multi Axis Positioning Motion Controller

The diagram below shows a PMD Magellan MC58000 series or MC55000 series multi-axis motion control IC being used with two or more Atlas Amplifiers to provide control of brushless DC, DC Brush, or Step Motors in a positioning application. If desired each axis can control a different motor type, so that, for example, brushless DC motors can be used along with step motors in the same controller.

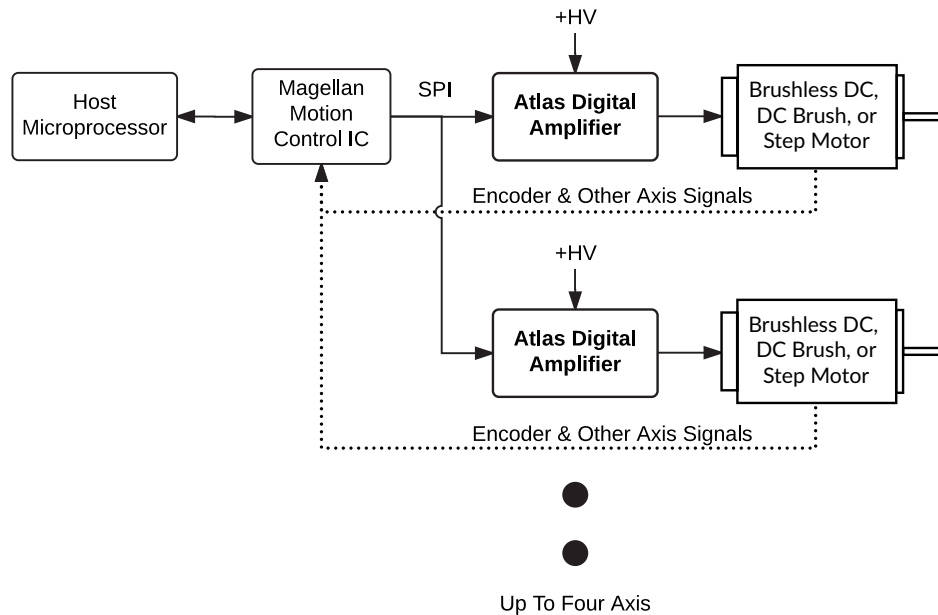

Figure 1-2:
Multi Axis
Magellan With
Atlas
Amplifiers

1.2.3 Microprocessor-Based Motion Controller

The diagram below shows the Atlas Amplifier being driven by a general purpose microprocessor that provides high level path generation and servo loop closure and outputs continuous desired torque commands or desired position increments for step motors to the Atlas Amplifier via the SPI (Serial Peripheral Interface).

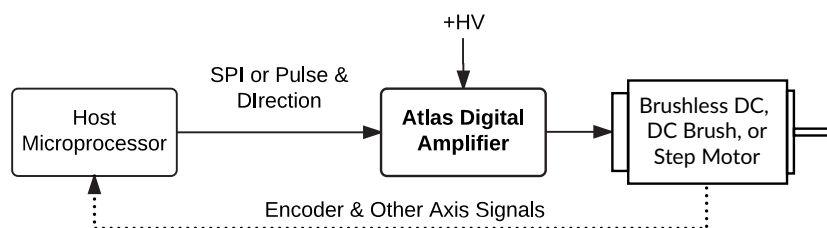
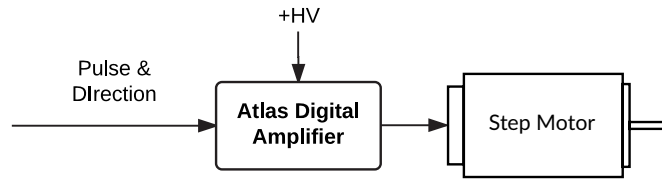

Figure 1-3:
Direct Host
Microprocessor
With Atlas
Amplifiers

1.2.4 Stand Alone Step Motor Amplifier

The diagram below shows the Atlas Amplifier being directly driven by pulse & direction signals. These signals may come from a microprocessor, a control card, or any other existing motion control device that outputs pulse & direction signals. In this mode the Atlas unit operates 'stand-alone,' and utilizes configuration control parameters previously stored into the Atlas unit's NVRAM (non-volatile) memory.

**Figure 1-4:
Direct Host
Microprocessor
With Atlas
Amplifiers**



There are a few options for configuring Atlas units for stand alone operation:

- Pro-Motion can be used with the Atlas Developer's Kit to program Atlas units
- The user can develop their own NVRAM programming system by utilizing the SPI (Serial Peripheral Interface) Atlas command protocol. For more information refer to the *Atlas Digital Amplifier Complete Technical Reference*.
- PMD offers custom pre-configured Atlas units. For more information contact your local PMD sales representative.

1.2.5 Force Control

The Brushless DC and DC Servo Atlas units can be used for general purpose force control applications such as remote teleoperation, force feedback, solenoid actuation, and any other general purpose valve/actuator control where a precisely controllable current is needed.

In this application the torque command may be sent continuously by the host microprocessor or from time to time as required by the application. In either case the Atlas provides very accurate current/torque control resulting in smooth and precise application of force.

**Figure 1-5:
Atlas Force
Control**

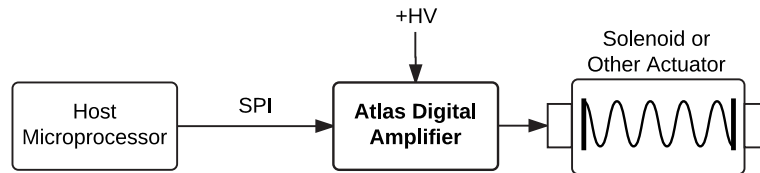

1.3 Features and Functions

The Atlas family of amplifiers provide an extensive list of functions, including:

- Available in Brushless DC, DC Brush, Step Motor, and multi-motor motor types
- High performance all-digital power amplifier
- Works with Magellan ICs, FPGAs or microprocessor-based controllers
- Digital SPI interface eliminates analog +/- 10V signals
- Available in 75W, 250W, and 500W+ power levels
- Rugged plastic solderable module format uses standard through-hole pins
- Total power output to 1Kilowatt
- Available in ultra compact 1.05" x 1.05" x .53" (27mm x 27mm x 13mm) size or compact 1.52" x 1.52" x .60" (39mm x 39mm x 15mm) size

- Horizontal and vertical mount configurations
- Includes rugged mechanical tab mounts
- Supply voltage range of 12V up to 56V
- High current output up to 14A continuous, 25A peak
- Digital current loop with choice of standard A/B or Field Oriented Control (FOC)
- Direct signal pulse and direction input
- I^2t current foldback limiting
- Overcurrent, overvoltage, undervoltage, overtemperature, and SPI command watchdog timeout protection
- Single DC supply operation.
- Enable input and FaultOut output safety interlock signals
- SPI (Serial Peripheral Interface) up to 8 MHz
- Performance trace of up to 1,020 words and four simultaneous variables
- 1,024 word non-volatile parameter storage
- Microstepping control with up to 256 microsteps per full step
- Signal conditioning buffers and analog filters on all I/O signals
- Fully RoHS compliant and CE marked

1.4 Atlas Developer Kits

To simplify development, four different Atlas Developer Kits are available, reflecting a choice of one or four axis board, and a choice of two different Atlas mounting configurations; vertical and horizontal. The following table shows this:

Developer Kit P/N	# of Axes	Atlas Type
MDK1LI0000V	1	Vertical
MDK1LI0000H	1	Horizontal
MDK4LI0000V	4	Vertical
MDK4LI0000H	4	Horizontal

[Figure 1-6](#) shows an overview of an Atlas Developer Kit assembly. The particular assembly shown is for a four axis vertical DK, but the overall elements are similar for one axis developer kits. Horizontal developer kits are also similar except that there is no vertical plate included. Note that the Atlas units shown in the figure are not included with the developer kit and must be purchased separately.

Figure 1-6:
Developer Kit
Components

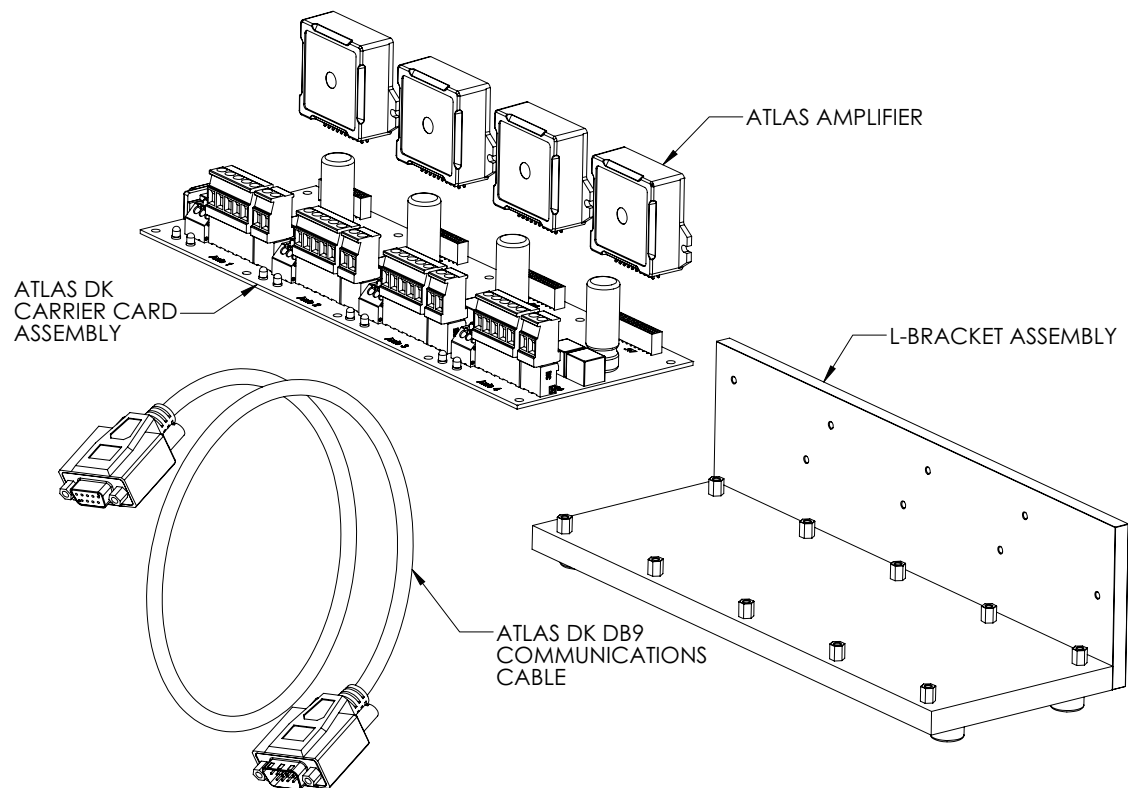

The following software and hardware components are included in every Atlas Developer Kit:

- Pro-Motion Windows-based exerciser software
- C-Motion and VB-Motion SDK
- PDFs of all documentation
- Atlas DK DB9 communications cable

The Atlas DK boards are designed for direct use with the compact Atlas format however each DK includes converter cards that allow the ultra compact Atlas to be plugged into the compact Atlas DK board socket.

Vertical Atlas DKs include an L-bracket vertical plate which provides a stable mechanical base from which you can operate your prototype system motors. With the vertical plate, the Atlas units have additional heat sinking, which can be extended further by connecting the vertical plate to your own heat sink or cold plate. Horizontal Atlas DKs utilize individual heat sinks which are included with the DK.

Electrical connection to the Atlas DK board is made by DB9 connector, and by jack screw connectors. Designers who plan to use the Atlas in conjunction with PMD's Magellan Motion Control ICs can connect the Atlas DK to the MC58113 or Magellan DK card, purchased separately. For more information on these products see one of the available Magellan Motion Control IC developer kit user manuals.

Refer to [Appendix A, "Atlas Developer Kits"](#) for complete information on ordering, setting up and operating the Atlas DK.

This page intentionally left blank.

2. Functional Characteristics

In This Chapter

- ▶ Operational Specifications
- ▶ Physical Dimensions
- ▶ Mechanical Mounting Options

2.1 Operational Specifications

Operating Parameter	Value
Motor types supported:	Brushless DC, DC Servo, Step Motor
Communication format:	SPI (Serial Peripheral Interface)
SPI clock frequency range:	2.0 MHz to 8.0 MHz
Torque command rate:	up to 9.7 kHz
Current measurement resolution:	12 bits
Current loop type:	P, I (proportional, integral) with Integral limit
Current loop resolution:	16 bits
Current loop rate:	19.530 kHz
Current loop modes:	individual phase, field oriented control, third leg floating
Safety functions:	over current detect, programmable over temperature detect, programmable overvoltage detect, programmable under voltage detect, programmable I ² t current foldback, SPI command watchdog timeout
Output limiting:	Programmable I ² t energy, current, and voltage limit
Command modes:	SPI voltage, SPI torque, pulse & direction signal
PWM rate:	20 kHz, 40 kHz, 80 kHz, or 120 kHz
PWM generation modes:	sinusoidal, space vector modulation, standard single-phase
Pulse & direction rate:	1.0 M Pulses/sec
Microsteps per full step:	up 256 per full step
Trace capture modes:	one time, rolling-buffer
Trace trigger modes:	internal clock, external by controller
Trace buffer size:	1,020 16-bit words
NVRAM storage size:	1,024 16-bit words

2.2 Physical Dimensions

2.2.1 Vertical Unit, Ultra Compact Package

Figure 2-1:
Vertical Unit -
Ultra Compact
Package

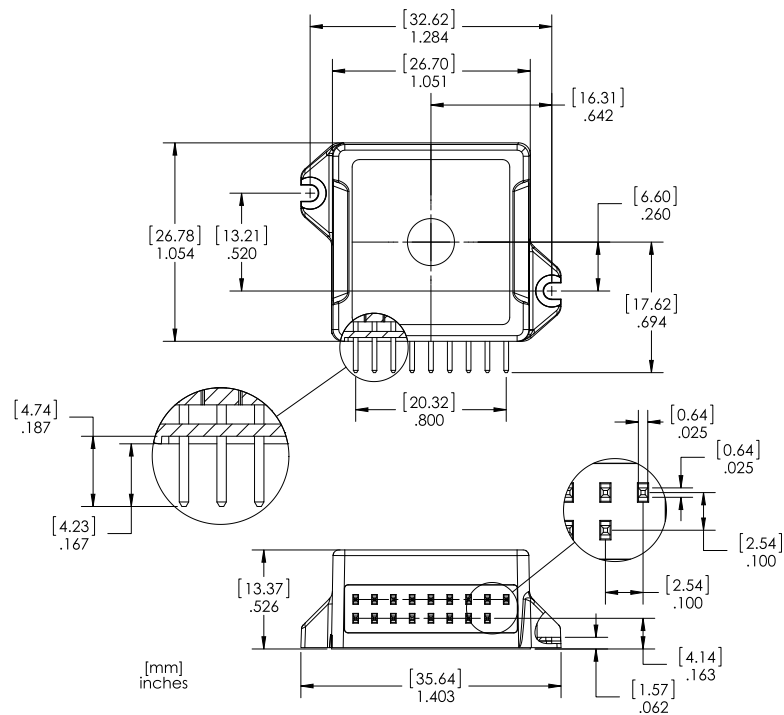

2.2.2 Horizontal Unit, Ultra Compact Package

Figure 2-2:
Horizontal Unit -
Ultra Compact
Package

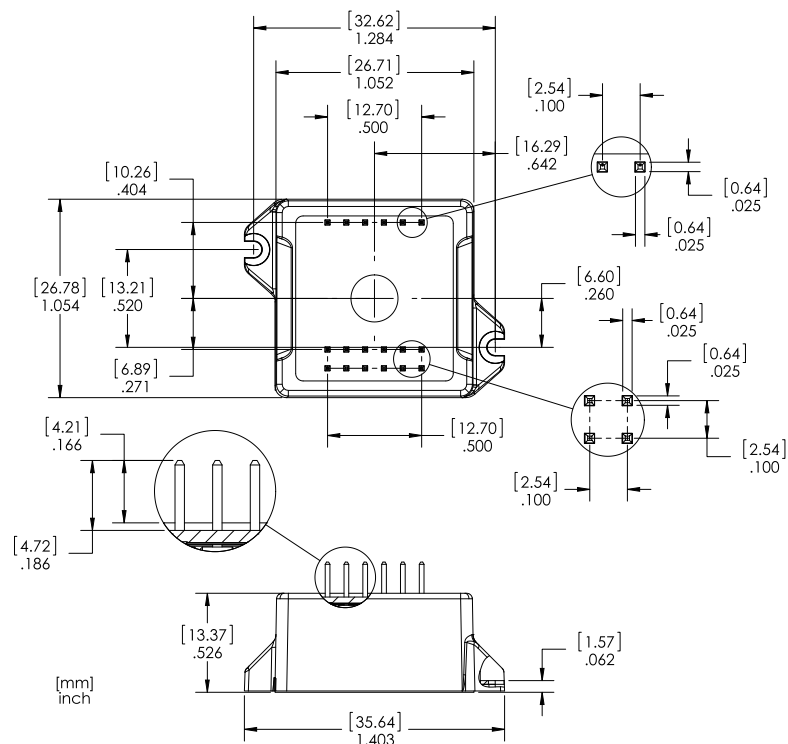

2.2.3 Vertical Unit, Compact Package

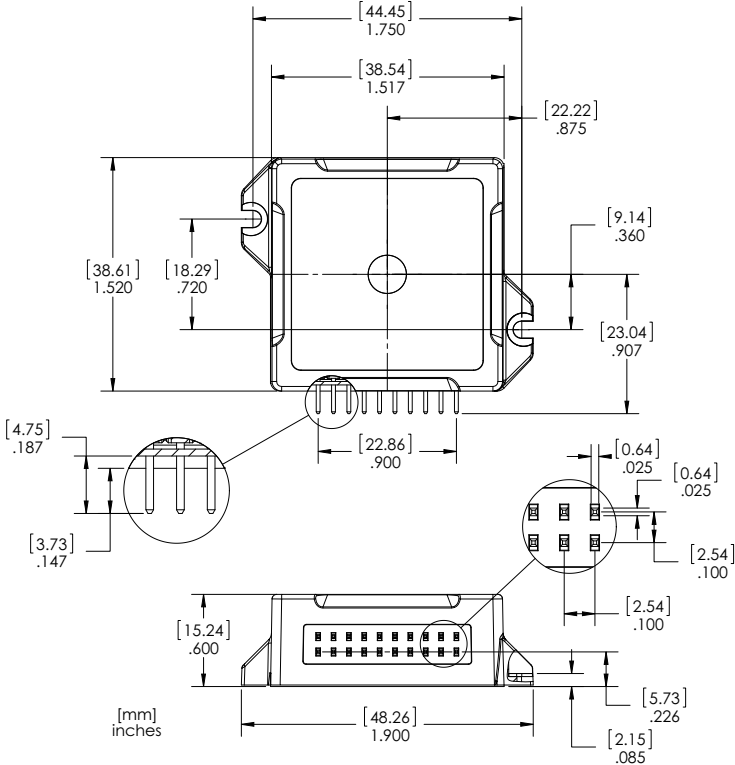

Figure 2-3: Vertical Unit - Compact Package

2.2.4 Horizontal Unit, Compact Package

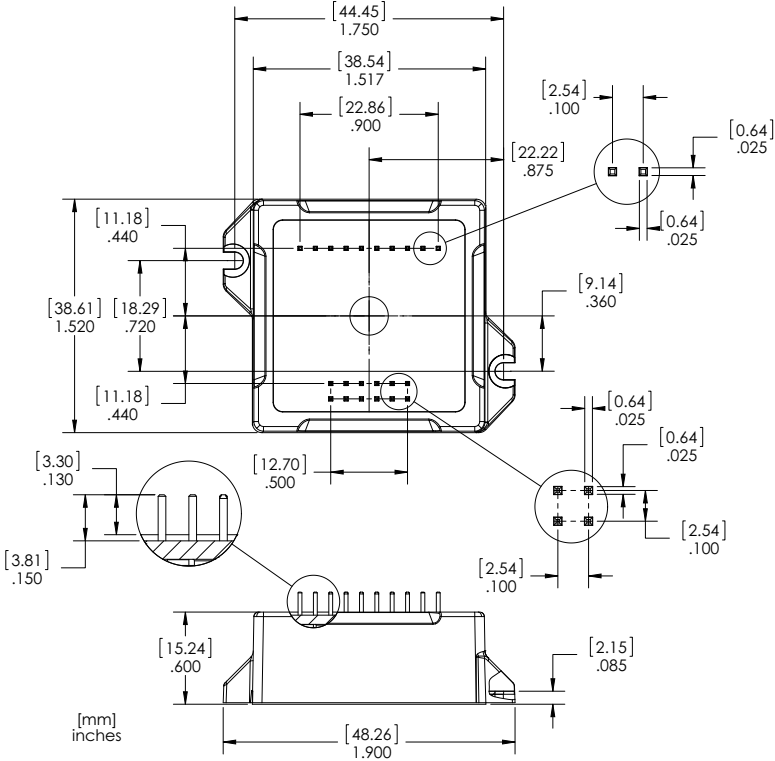

Figure 2-4: Horizontal Unit - Compact Package

2.3 Mechanical Mounting Options

Atlas amplifiers are provided in two separate package sizes, ultra compact and compact, and in two separate mounting configurations; vertical and horizontal. There are some very low power applications where the Atlas unit may be mounted without mechanical attachment to the screw tabs. In such cases mechanical attachment to the PCB occurs via the electrical solder connections.

Most applications however will utilize the Atlas unit's integral screw tab mounts to rigidly connect the Atlas to the PCB, to a heat sink, or to some other mechanical support. As shown in Figure 2-5 there are a number of Atlas mounting options available when using the Atlas screw tabs. The choice of the mounting hardware depends on the demands of the application.

The following table provides information related to the mechanical screw tab mounts:

Atlas Package	Recommended screw type	Maximum screw head diameter	Maximum screw body diameter
Ultra Compact	M2.0	4.2 mm	2.2 mm
Compact	M2.5	5.4 mm	2.8 mm

Figure 2-5: Horizontal & Vertical Unit Mounting Options

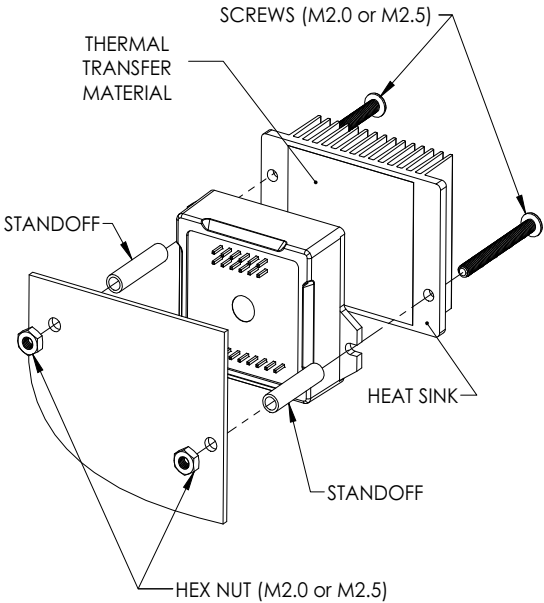

A Horizontal Unit, Mechanical Mount Through Heat Sink to PCB

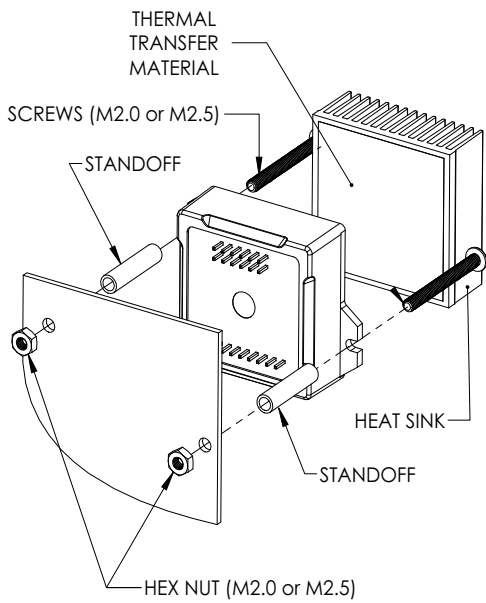

B Horizontal Unit, Mechanical Mount to PCB

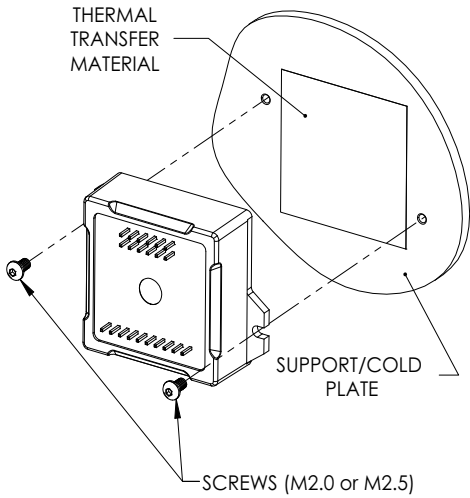

C Horizontal Unit, Mechanical Mount to Support/Cold Plate

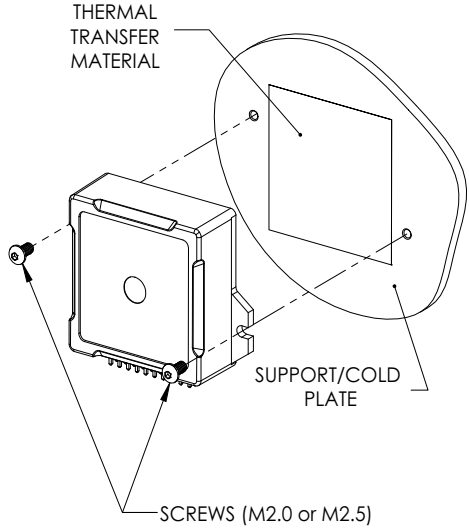

D Vertical Unit, Mechanical Mount to Support/Cold Plate

2.3.1 Mounting Guidelines

Atlas amplifiers, while designed to be robust and easy to install, contain active electronics that can only function reliably when the mechanical integrity and operating environment of the Atlas is maintained. The next three sections

provide important recommendations and guidelines for the configuration, selection, placement, mounting method, and installation procedure for Atlas amplifiers.

Choice of vertical or horizontal Atlas. The horizontal configuration of Atlas is recommended for applications where the Atlas is not mechanically mated to a supporting plate and where vibration or movement-related forces may be present. When the Atlas unit is mechanically mated to a supporting plate, either the horizontal or the vertical configuration may be used. [Figure 2-5C](#) and [Figure 2-5D](#) show the Atlas unit mechanically mated to a supporting plate.

Attaching Atlas to a supporting plate. Some Atlas applications will utilize a supporting plate for heat removal or for enhanced mechanical stability. For Atlas installations that may be subject to vibration or movement-related forces and that utilize a supporting plate, special care should be taken to insure that there is no movement between the circuit card that the Atlas is soldered or socketed to and the supporting plate which the Atlas is mechanically attached to. Such movement could result in damage to the Atlas unit, the circuit card, or the supporting plate.

Attaching Atlas to a free-standing heatsink. Some Atlas applications will utilize a free standing heat sink, such as is shown in [Figure 2-5A](#) and [Figure 2-5B](#). Free standing heat sinks are recommended with horizontal Atlas units but are not recommended for use with vertical Atlas units. When mounting Atlas units with free standing heat sinks special care should be taken where vibration or movement-related forces may be present. These forces, acting on the additional mass of the heat sink, may impart excessive mechanical stress on the Atlas resulting in damage to the Atlas unit, the circuit card, or the heat sink. Depending on the nature and magnitude of the forces, in these applications mounting the Atlas to a supporting plate may be preferred.

Choice of socket or solder connection to the circuit card. For best electrical contact to the printed circuit board (PCB), connection by soldering to the Atlas is generally recommended. This is particularly true for Atlas units that are not mated to a supporting plate. When the Atlas unit is mounted to a supporting plate either solder or socket electrical connections may be used, with solder connections recommended for applications benefitting from rigid connection of the Atlas to the PCB, and sockets being recommended when greater mechanical isolation of the PCB from the mechanical support is desired.



Some of the electrical ratings of the Atlas may not be achievable when electrical connection to the Atlas is via sockets rather than via soldering. It is the responsibility of the user to determine whether a particular motor output current and voltage rating may be achieved with a given socket.

2.3.2 Thermal Transfer Materials

Thermal transfer materials in the form of thermal tape, pads, paste, or epoxy may be used to improve thermal transfer between the Atlas' metal plate and an attached heat sink or supporting plate. These materials improve thermal conductivity by filling in air gaps that form when two metallic surfaces are mated.

[Figure 2-5](#) shows a typical application of a thermal transfer material between the Atlas and a heat-removing metal surface. The following guidelines may be helpful in selecting and sizing the thermal transfer material best-suited to your application.

The capacity of thermal transfer materials to transfer heat (known as the bulk conductivity) is much lower than that of metals such as aluminum or copper. Therefore, in general, the thinner the transfer material the better. Thickness of the material is only precisely controllable for thermal pads and thermal tapes, with thermal pads providing the thinnest available interfaces beginning at 5 mils (.127 mm) or even less. For use with Atlas amplifiers thermal transfer materials that are thicker than 40 mils (1.0 mm) are not recommended regardless of the material used.

When using thermal paste or thermal epoxy glue the thickness should be carefully controlled via a silk screen or other wet film application process. The Atlas unit itself should not be used to squeeze non-uniformly applied paste or epoxy flat during installation. Doing so may result in damage to the Atlas.

Whether using tape, pads, paste, or epoxy, as shown in [Figure 2-6](#), the thermal transfer material that is used as the interface should not extend to the area under the Atlas' tabs because this may reduce the amount of compression that occurs in the thermal transfer area. The following table provides dimensions for the applied thermal transfer material for the two available Atlas package sizes:

Atlas Package Size	Maximum Pad Dimensions
Ultra Compact	.1.00" x .95" (25.4 mm x 24.1mm)
Compact	1.40" x 1.50" (35.6 mm x 38.1 mm)

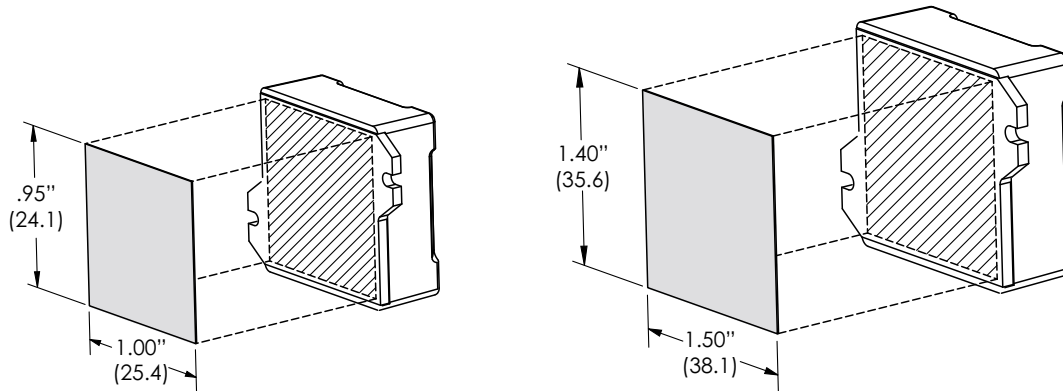

Figure 2-6:
Recommended
Atlas Unit
Thermal
Transfer
Material
Dimensions

2.3.3 Atlas Installation

There are a number of precautions and procedures that should be followed to maintain the electrical and mechanical integrity of the Atlas unit during installation.

Soldering Atlas units in place. Applications that utilize Atlas units that are not mechanically mated to a heat sink or that are mated to a self-standing heat sink may utilize a standard soldering process without special precautions or procedures. Applications that involve Atlas units mated to a supporting plate and that will be soldered to the PCB should take special care to insure that the solder joints are not stressed by the supporting plate once installed. The recommended method to achieve this is to mechanically mate the Atlas to the supporting plate before soldering the Atlas into the PCB. If, for whatever reason, this is not possible, then special care should be taken to insure that the Atlas is precisely aligned with the supporting plate after soldering and before mechanical attachment so that upon mechanical attachment no stress is placed on the Atlas unit, the solder contacts, or the PCB.

Mounting surface flat and clean. Thermal performance as well as safe operation of the Atlas requires that the surface that the Atlas is mounted to be flat and clean, free of dust, grease, or foreign objects. The recommended maximum deviation of the mating surface flatness is 3 mils (.076 mm).

Mechanical mounting limits. Applications that will utilize a mechanical attachment to the Atlas via the Atlas's mounting tabs should take special care not to overstress the mechanical tabs. Regardless of the attachment method, which is most commonly screws but may also be clips or inserts, the linear force applied to each mechanical tab should not exceed certain values as shown in the following table and the accompanying [Figure 2-7](#).

Atlas Package Size	Maximum Direct Force Per Tab	Screw Type, Corresponding Maximum Rotary Torque
Ultra Compact	25 pounds (111 N)	M2.0 x .40, 11.0oz-in (.078 N-m)
Compact	35 pounds (156 N)	M2.5 x.45, 12.5oz-in (.088 N-m)

**Figure 2-7:
Atlas Torque
Specifications**

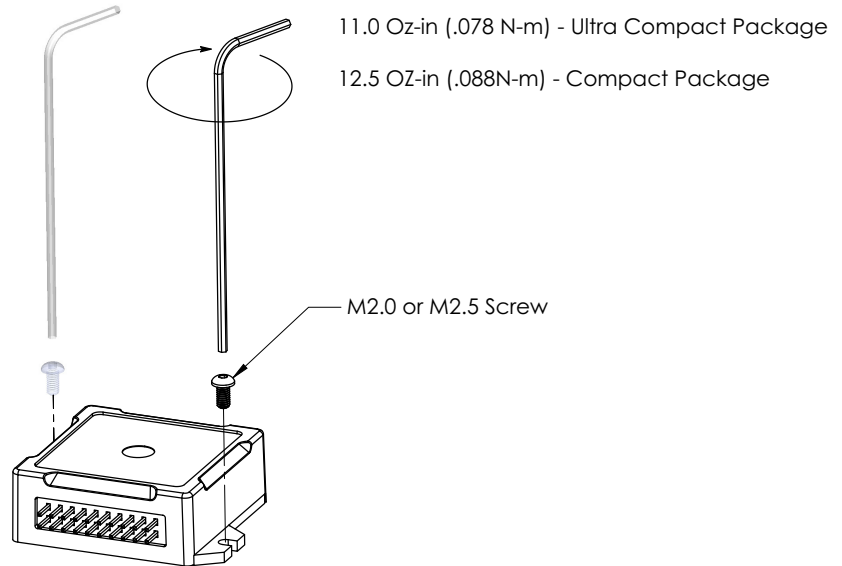

Mechanical mounting procedure. Atlas units that are mated to a heat sink or mechanical plate should be attached by progressively tightening both of the Atlas unit's tabs. This means that one screw may be tightened, followed by the other, than back to the first etc. until the desired torque at each screw has been achieved. Following this procedure is particularly important when installing Atlas units over paste or epoxy, where the subsurface layer will undergo compression and movement before settling to a final installed position.



To ensure that proper contact exists between the Atlas and the entire thermal transfer material substrate, and to ensure that the Atlas unit is not damaged via mechanical overstress, the user should carefully apply equal torque increments to each tab screw, never exceeding at any point the torque limit on either tab of 25 lbs (111 N) linear force or 11.0 oz-in (.078 N-m) rotary torque using a M2.0 x .40 screw for the ultra compact Atlas package, and 35 lbs(156N) linear force or 12.5oz-in (.088 N-m) rotary torque using a M2.5 x .45screw for the compact Atlas package.



It is the responsibility of the user to ensure that all Atlas units have been installed within the above prescribed mechanical stress limits and following the above described procedures. Failure to observe any of the above recommended procedures and limits may result in incorrect operation or failure of the Atlas during operation.

3. Electrical Specifications

In This Chapter

- ▶ Drive Ratings
- ▶ Absolute Maximum Ratings
- ▶ Environmental Ratings
- ▶ Safety and Compliance
- ▶ DC Characteristics
- ▶ AC Characteristics
- ▶ Pin Descriptions and Pinouts
- ▶ Signal Interfacing
- ▶ Connection Overview
- ▶ Heat Sink Grounding
- ▶ Atlas Conversion Factors

3.1 Drive Ratings

3.1.1 Low Power Units (P/Ns MD2x1048/02xB)

Specifications*	DC Brush Motor	Brushless DC Motor	Step Motor
Nominal supply voltage	12-48 VDC	12-48 VDC	12-48 VDC
Continuous current	1.5 ADC	1.5 Arms	1.5 Arms
Peak current (per phase)	3.8 A	3.8 A	3.8 A
Maximum continuous power	72 W	88 W	102 W

* transformer isolated power supply, T < 40° C

A coldplate or a heatsink in an environment with sufficient airflow can be used to achieve the above drive ratings.

For temperature operation beyond the standard 0-40° C range, above-listed ratings may change. Contact your PMD representative for additional information on Atlas extended temperature operation including higher temperature drive ratings.

3.1.2 Medium Power Units (P/Ns MD2x1048/05xB)

Specifications*	DC Brush Motor	Brushless DC Motor	Step Motor
Nominal supply voltage	12-48 VDC	12-48 VDC	12-48 VDC
Continuous current	7.0 ADC	5 Arms	4.5 Arms
Peak current (per phase)	12.5 A	12.5 A	12.5 A
Maximum continuous power	336 W	294 W	305 W

* transformer isolated power supply, $T < 40^{\circ} \text{C}$

A coldplate or a heatsink in an environment with sufficient airflow can be used to achieve the above drive ratings.

For temperature operation beyond the standard 0-40° C range, above-listed ratings may change. Contact your PMD representative for additional information on Atlas extended temperature operation including higher temperature drive ratings.

3.1.3 High Power Units (P/Ns MD2x1056/25xB)

Specifications*	DC Brush Motor	Brushless DC Motor	Step Motor
Nominal supply voltage	12-56 VDC	12-56 VDC	12-56 VDC
Continuous current	14.0 ADC	10.0 Arms	9.0 Arms
Peak current (per phase)	25.0 A	25.0 A	25.0 A
Maximum continuous power	670 W	590 W	610 W

* transformer isolated power supply, $T < 40^{\circ} \text{C}$

A coldplate or a heatsink in an environment with sufficient airflow can be used to achieve the above drive ratings.

For temperature operation beyond the standard 0-40° C range, above-listed ratings may change. Contact your PMD representative for additional information on Atlas extended temperature operation including higher temperature drive ratings.

3.2 Absolute Maximum Ratings

Parameter	Rating
HV voltage range, low power units	0 V to +52 V
HV voltage range, medium power units	0 V to +52 V
HV voltage range, high power units	0 V to +60 V
~Enable voltage range	-10 V to +24 V
SPISl, SPIClk, ~SPICS voltage range	-0.5 V to 6.5 V
SPISO voltage range	-0.5 V to 3.7 V
FaultOut voltage range	-0.3 V to 24 V
FaultOut output current	-35 μA to 50 mA
5V output current, low power units	50 mA
5V output current, medium power units	50 mA
5V output current, high power units	100 mA



All voltage values are with respect to GND unless otherwise noted.

3.3 Environmental Ratings

Specification	Value
Operating ambient temperature	0 to 40 C
Maximum base plate temperature	75 C
Storage temperature	-20 to 85 C
Reflow soldering temperature	300 C (1.5mm for 10 seconds)
Humidity	0 to 95%, non-condensing
Altitude	Up to 2,000 meters without derating
Contamination	Pollution Degree 2

3.4 Safety and Compliance

Specification	Standard
CE	LVD: EN60204-1 EMC-D: EN61000-6-1, EN61000-6-3, EN55011
Electrical safety	Designed to UL508C, UL840 and EN60204-1
Hazardous materials	RoHS compliant
Flammability	UL94-HB
Enclosure	IP20

3.5 DC Characteristics

3.5.1 SPIS1, SPIC1k

Schmitt-trigger Input	Min	Max	Conditions
V ₊ , Positive-going input threshold voltage	1.6 V	2.0 V	
V ₋ , Negative-going input threshold voltage	0.9 V	1.2 V	
V _T , Hysteresis V ₊ -V ₋	0.6 V	1.0 V	
I _{IN} , input current		±1 uA	Input voltage is 5.5 V or GND

3.5.2 SPIS0

	Min	Max	Conditions
V _O , output voltage	0	3.3 V	
V _{OH} , Logic 1 output voltage	3.2 V		I _{OH} =-100 uA
	2.4 V		I _{OH} =-16 mA
V _{OL} , Logic 0 output voltage		0.1 V	I _{OL} =100 uA
		0.7 V	I _{OL} =16 mA
I _{OZ} , input current when ~SPICS is "1"		10 uA	V _O = 0 to 3.7 V

3.5.3 ~SPICS

	Min	TYP	Max	Conditions
V_{IH} , Logic 1 input voltage	2 V			
V_{IL} , Logic 0 input voltage			0.8 V	
I_{IN} , pull-up current		-500 μ A		

3.5.4 ~Enable

Schmitt-trigger input	Min	Max	Conditions
V_{+} , Positive-going input threshold voltage	1.6 V	2.0 V	
V_{-} , Negative-going input threshold voltage	0.9 V	1.2 V	
VT, Hysteresis V_{+} - V_{-}	0.6 V	1.0 V	

3.5.5 FaultOut

	Min	Max	Conditions
Output impedance with Logic 1 output	148 Kohm	152 Kohm	$I_{OH}=-100 \mu$ A
V_{OL} , Logic 0 output voltage		0.25 V	$I_{OL}=10$ mA

3.5.6 5V

	Min	Max	Conditions
Voltage tolerance, low power units	-5%	5%	Output current 0-50 mA
Voltage tolerance, medium power units	-5%	5%	Output current 0-50 mA
Voltage tolerance, high power units	-5%	5%	Output current 0-100 mA
Short circuit protection	Not available		

3.6 AC Characteristics

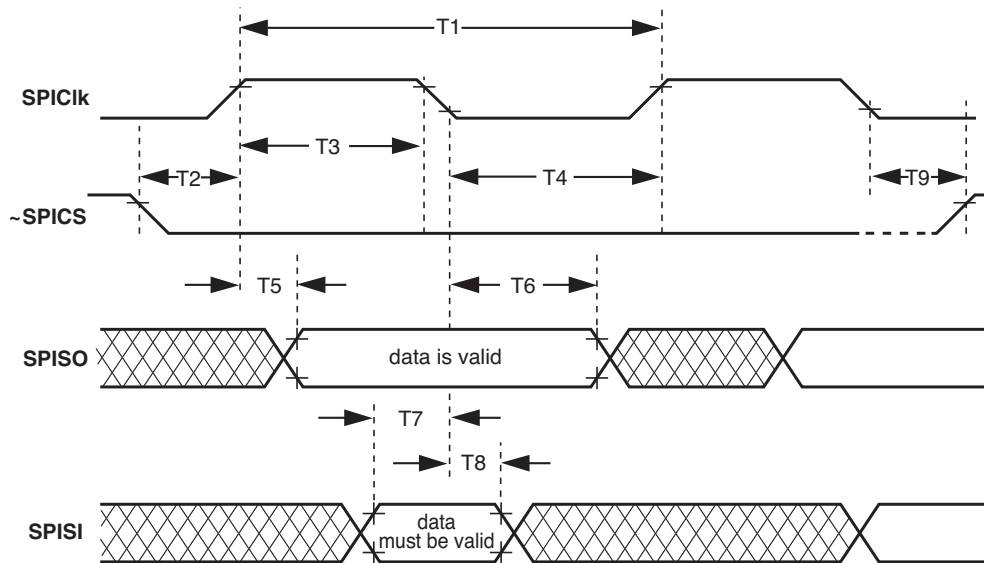

Figure 3-1:
Timing
Diagrams

See [Figure 3-1](#) for timing numbers.

Timing Interval	No.	Min	Max
T_{SPI} , SPI clock cycle time	T1	125 nsec	
Pulse duration, SPIClk high	T3	$(0.5 T_{SPI} - 10)$ nsec	
Pulse duration, SPIClk low	T4	$(0.5 T_{SPI} - 10)$ nsec	
SPIClk high to SPISO valid delay time	T5		30 nsec
SPISO data valid time after SPIClk low	T6	$(0.75 T_{SPI} + 2.2)$ nsec	
SPISI setup time before SPIClk low	T7	30 nsec	
SPISI valid time after SPIClk low	T8	$(0.5 T_{SPI} - 6)$ nsec	
~SPICS low to first SPIClk high	T2	400 nsec	
Last SPIClk low to ~SPICS high	T9	$0.5 T_{SPI}$	

3.7 Pin Descriptions and Pinouts

All Atlas units regardless of package size or mounting configuration provide a common set of signals and functions however the pin addresses and number of pins for various functions are different between the ultra compact Atlas units and the compact Atlas units. In addition, the pin addresses are different between the horizontal and vertical mounting configurations for each package size.

The following sections provide detailed pinouts for the two Atlas packages; ultra compact and compact, and the two mounting configuration; horizontal and vertical.

All Atlas unit pins are 0.1 inch spacing and 0.025inch pin width.

3.7.1 Atlas Pinouts - Ultra Compact, Vertical

Figure 3-2:
Atlas Pinouts -
Ultra Compact,
Vertical

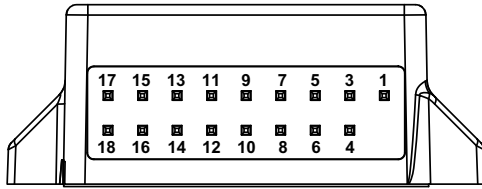

Pin	Name	Pin	Name
1	HV	2	
3	Motor A	4	Pwr_Gnd
5	Motor C	6	Motor B
7	Motor D	8	NC (No Connect)
9	NC (No Connect)	10	NC (No Connect)
11	~Enable	12	FaultOut
13	GND	14	5V
15	SPISO	16	~SPICS/AtRest
17	SPIClk/Pulse	18	SPIS/Direction



The ultra compact Atlas vertical package is keyed so that it is installation direction dependent. It has no physical pin installed at the Pin #2 location.

3.7.2 Atlas Pinouts - Ultra Compact, Horizontal

Figure 3-3:
Atlas Pinouts -
Ultra Compact,
Horizontal

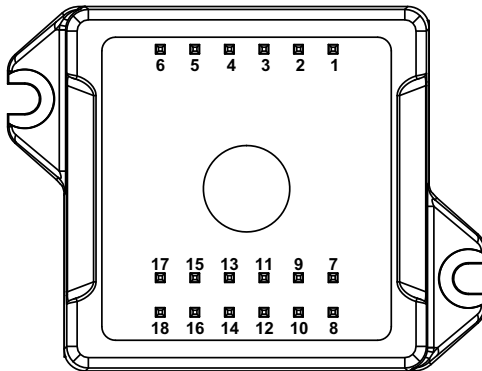

Pin	Name	Pin	Name
1	Motor D	2	Motor C
3	Motor B	4	Motor A
5	HV	6	Pwr_Gnd
7	SPIS/Direction	8	SPIClk/Pulse
9	SPISO	10	~SPICS/AtRest

11	5V	12	GND
13	FaultOut	14	~Enable
15	GND	16	NC (no connect)
17	NC (no connect)	18	NC (no connect)

3.7.3 Atlas Pinouts - Compact, Vertical

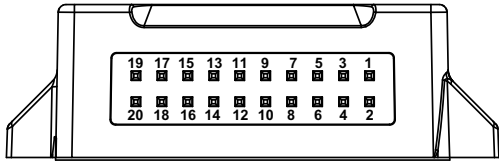

Figure 3-4:
Atlas Pinouts -
Compact,
Vertical

Pin	Name	Pin	Name
1	Pwr_Gnd	2	Pwr_Gnd
3	HV	4	HV
5	Motor A	6	Motor A
7	Motor B	8	Motor B
9	Motor C	10	Motor C
11	Motor D	12	Motor D
13	~Enable	14	FaultOut
15	5V	16	GND
17	~SPICs/AtRest	18	SPIS/Direction
19	SPIClk/Pulse	20	SPISO

The compact Atlas package provides additional power output via doubling of the HV, Pwr_Gnd, and Motor output pins. To achieve the rated unit power output be sure that both pins are connected.

The compact Atlas vertical package is not keyed and therefore care should be taken to install in the correct orientation.



3.7.4 Atlas Pinouts - Compact, Horizontal

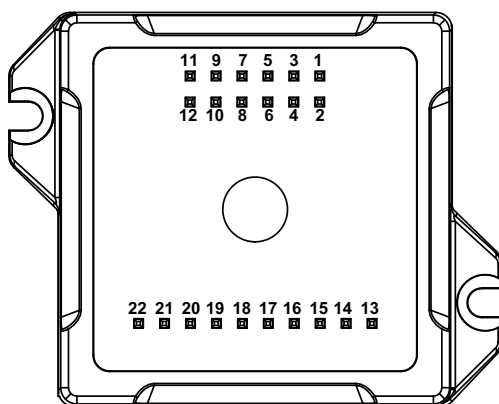

Figure 3-5:
Atlas Pinouts -
Compact,
Horizontal

Pin	Name	Pin	Name
1	Motor D	2	Motor D
3	Motor C	4	Motor C
5	Motor B	6	Motor B
7	Motor A	8	Motor A
9	HV	10	HV
11	Pwr_Gnd	12	Pwr_Gnd
13	5V	14	GND
15	~Enable	16	FaultOut
17	GND	18	~SPICS/AtRest
19	SPISO	20	SPIS/Direction
21	SPIClk/Pulse	22	GND

The compact Atlas package provides additional power output via doubling of the HV, Pwr_Gnd, and Motor output pins. To achieve the rated unit power output be sure that both pins are connected.

3.7.5 Pin Descriptions

Pin Name	Direction	Description
HV		DC power to Atlas module, referenced to Pwr_Gnd. The DC power source should be a transformer isolated power supply. For the compact Atlas package two pins carry this signal, so care should be taken to connect both pins.
Pwr_Gnd		Power return for HV, Motor A, Motor B, Motor C and Motor D. For the compact Atlas package two pins carry this signal, so care should be taken to connect both pins. For greatest EMI protection double shielded cables on the motor winding A, B, C, and D should be used with the inner shield connected to Pwr_Gnd and the outer shield connected to chassis ground.
Motor A		Motor output pin A. Used with Brushless DC, DC Brush, and Step Motors. For the compact Atlas package two pins carry this signal, so care should be taken to connect both pins.
Motor B		Motor output pin B. Used with Brushless DC, DC Brush, and Step Motors. For the compact Atlas package two pins carry this signal, so care should be taken to connect both pins.
Motor C		Motor output pin C. Used with Brushless DC, and Step Motors. For the compact Atlas package two pins carry this signal, so care should be taken to connect both pins.
Motor D		Motor output pin D. Used with Step Motors. For the compact Atlas package two pins carry this signal, so care should be taken to connect both pins.
~Enable	Input	~Enable is an active-low input. Should be tied or driven low for Atlas motor output to be active.
FaultOut	Output	FaultOut is high impedance when active. It provides programmable fault indication, and is low when inactive.
SPIClk/Pulse	Input	SPI input clock or Pulse signal. Pulse is used when Atlas is set to pulse & direction signal mode, and causes a position change command upon a high to low transition. Selection of signal interpretation for this pin is via the SPI communications bus. The default signal interpretation is SPIClk.
SPISO	Output	SPI data master in slave out signal. It goes to high impedance when ~SPICS is high. This pin is not used if Atlas is operating in pulse & direction signal mode.

Pin Name	Direction	Description
SPI/Direction	Input	SPI data master out slave in signal or Direction signal. Direction is used when Atlas is set to pulse & direction signal mode, and indicates the step direction. Low means the position decreases upon a high to low transition of the Pulse signal, and high means the position increases. Selection of signal interpretation for this pin is via the SPI communications bus. The default signal interpretation is SPI.
~SPICS/AtRest	Input	~SPICS signal or AtRest signal. ~SPICS enables SPI communication when transitioning low. The SPI block is disabled when ~SPICS is high. AtRest is used when Atlas is set to pulse & direction signal mode, and indicates that the step motor holding current should be used rather than the drive current. Selection of signal interpretation for this pin is via the SPI communications bus. The default signal interpretation is ~SPICS.
GND		Ground return for ~Enable, FaultOut, SPI or pulse & direction signals and 5V.
5V		5V output used to drive external circuitry.

3.8 Signal Interfacing

3.8.1 \sim Enable

\sim Enable and FaultOut signals are typically used to implement a safety interlock between the Atlas module and other portions of the system.

\sim Enable is an active low input that must be tied or driven low for the Atlas power output to be active. Its input buffer is shown in [Figure 3-6](#). The circuit accepts signals in the range of 0-24V and has TTL compatible, Schmidt trigger thresholds. It has a pull-up to 5V to allow direct interfacing to open collector enable sources without external pull-up resistor and a 1.3kHz R-C low-pass filter to reject noise.

Figure 3-6:
Signal
Interfacing
 \sim Enable

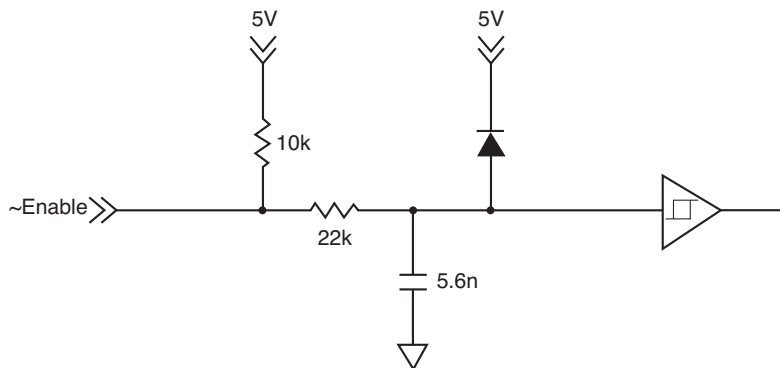

3.8.2 FaultOut

FaultOut is asserted high when a fault occurs. The external controller can select which fault conditions drive the *FaultOut* signal.

An Atlas FaultOut output circuit is shown in diagram [Figure 3-7](#). This circuit can continuously sink 50mA when pulled low. It has a 150kohm pull-up resistor to 5V. Its voltage range is 0 to 24V.

Figure 3-7:
Signal
Interfacing
FaultOut

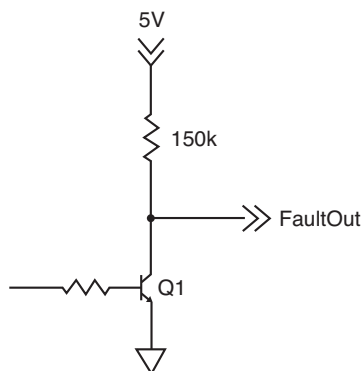

3.9 Connection Overview

3.9.1 Brushless DC Motors

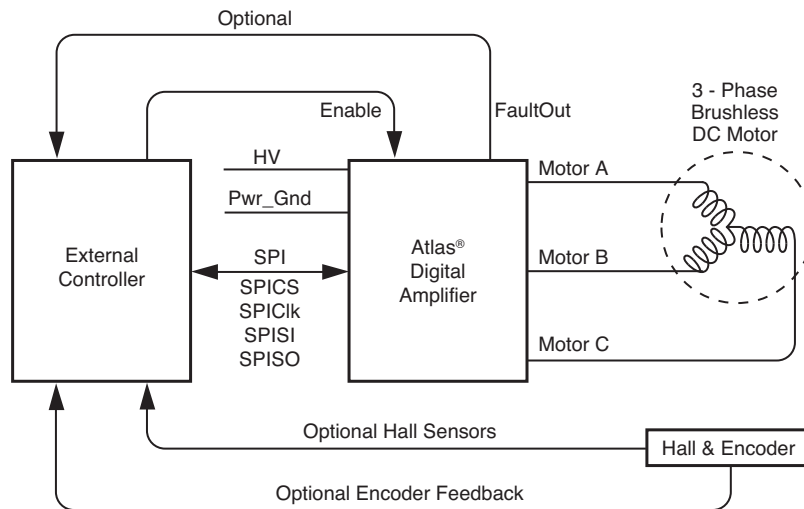

Figure 3-8:
Brushless DC
Connections

The following table summarizes the recommended connections when connecting Atlas amplifiers to brushless DC motors

Type	Required Connections	Optional Connections
Power	HV, Pwr_Gnd	
Communication	~SPICS, SPISO, SPISI, SPIClk, GND	
Motor	Motor A, Motor B, Motor C	
Miscellaneous	~Enable	FaultOut

If Atlas is used as part of a higher level position controller, as shown in the [Figure 3-8](#), the Brushless DC motor provides feedback signals to the external controller. Commonly, both Hall sensor signals and a position encoder are used, but only one or the other is needed in a minimal configuration. In this configuration the external controller generally consists of a PMD Magellan Motion Processor or a programmable microprocessor or DSP-type device.

Alternatively, Atlas can be operated by an external controller as a standalone device, driving the motor at commanded voltage or torque levels and not part of a higher-level servo controller. In this configuration, the external controller can be either a microprocessor-type device, or a logic device such as an FPGA (field programmable gate array).

Atlas functions as a power block providing amplification, current control, and safety management of the amplifier and motor. Atlas does not directly accept Hall signals or encoder signals, so to operate with a brushless DC motor the motor's current phase angle must be provided by the external controller through the SPI interface.

The Atlas does not support direct Hall signal inputs. To operate the Atlas with a Brushless DC motor, continuous motor phase angle is provided by the external controller, via either Hall inputs or an encoder.



3.9.2 DC Brush Motors

**Figure 3-9:
DC Brush
Connections**

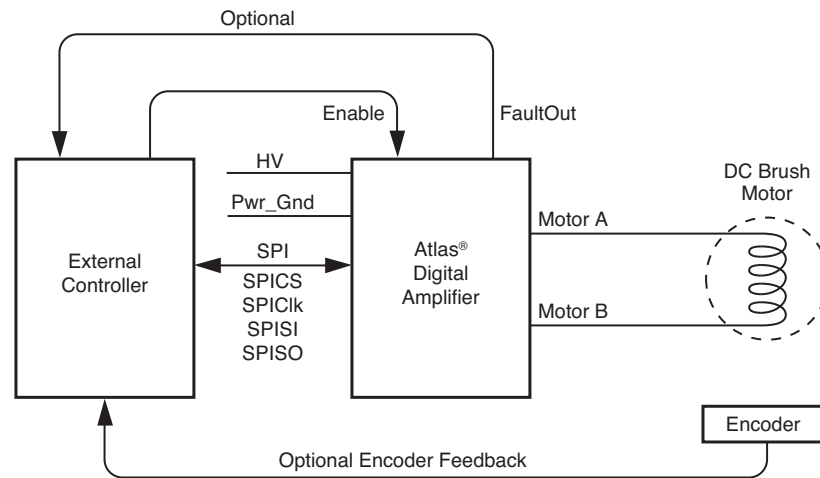

The following table summarizes the recommended connections when connecting Atlas amplifiers to DC Brush motors.

Type	Required Connections	Optional Connections
Power	HV, Pwr_Gnd	
Communication	~SPICs, SPISo, SPISi, SPICk, GND	
Motor	Motor A, Motor B	
Miscellaneous	~Enable	FaultOut

If Atlas is used as part of a higher level servo controller, as shown in [Figure 3-9](#), an encoder provides position or velocity feedback signals to the external controller. In this configuration the external controller generally consists of a PMD Magellan Motion Processor or a programmable microprocessor or DSP-type device.

Alternatively, Atlas can be operated by an external controller as a standalone device, driving the motor at commanded voltage or torque levels. In this configuration the external controller can be either a microprocessor-type device, or a logic device such as an FPGA (field programmable gate array).

3.9.3 Step Motors in Pulse & Direction Signal Mode

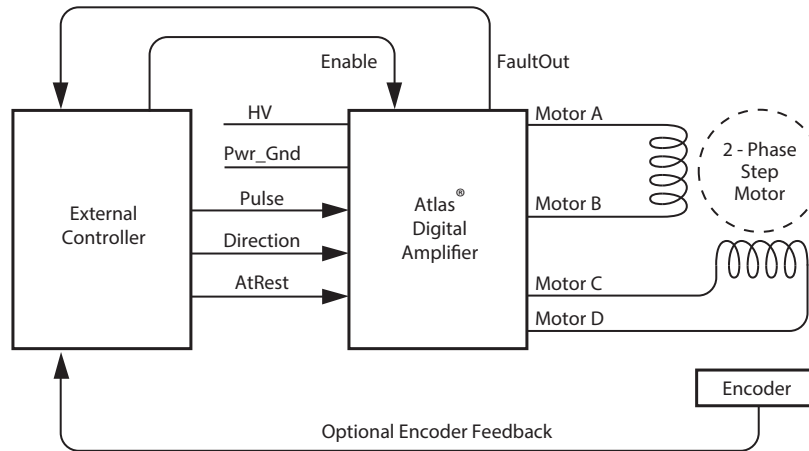

Figure 3-10:
Step Motor
Pulse and
Direction Mode
Connections

The following table summarizes the recommended connections when connecting Atlas amplifiers to two-phase step motors when using the pulse & direction signal mode. In this mode the external controller provides position commands to Atlas via pulse and direction signals.

Type	Required Connections	Optional Connections
Power	HV, Pwr_Gnd	
Communication	Pulse, Direction, GND	AtRest
Motor, Phase A ⁺ :	Motor A	
Motor, Phase A ⁻ :	Motor B	
Motor, Phase B ⁺ :	Motor C	
Motor, Phase B ⁻ :	Motor D	
Miscellaneous	~Enable	FaultOut

These connections apply to bipolar motors. If connecting to unipolar motors do not connect the center tap.

In this configuration the external controller generally consists of an off-the-shelf motion control card or module, a programmable microprocessor or DSP-type device, or a FPGA (field programmable gate array). The external controller provides a continuous stream of pulse and direction commands, along with (optionally) an *AtRest* signal to control the torque.

To initially set up and store its application-specific configuration parameters, Atlas is programmed using the SPI interface and then commanded to convert to pulse & direction signal mode.

FaultOut signal input to external controller is strongly recommended when the Atlas is used in Pulse & Direction signal mode.

3.9.4 Step Motors Using SPI Communications

Figure 3-11:
Step Motor
SPI Communi-
cation Connec-
tions

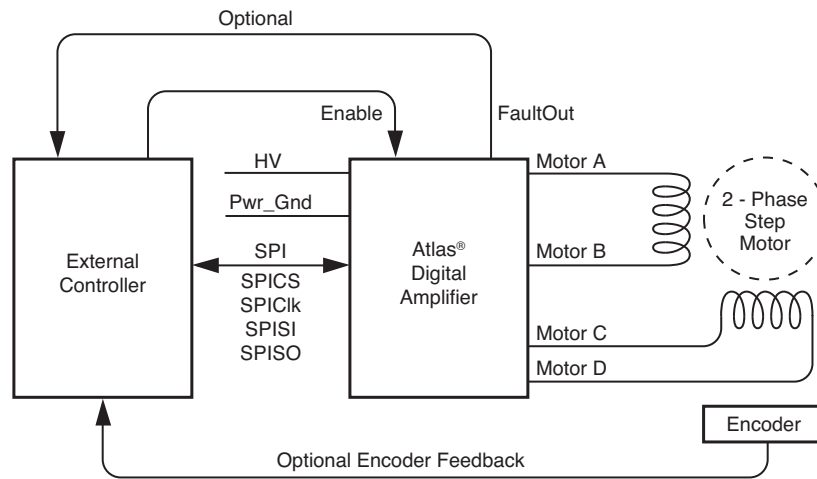

The following table summarizes the recommended connections when connecting Atlas amplifiers to two-phase step motors when using the SPI communications channel. In this mode the external controller provides position commands to Atlas via the SPI interface.

Type	Required Signal Connections	Optional Signal Connections
Power	HV, Pwr_Gnd	
Communication	~SPICS, SPISO, SPISI, SPICIk, GND	
Motor, Phase A ⁺ :	Motor A	
Motor, Phase A ⁻ :	Motor B	
Motor, Phase B ⁺ :	Motor C	
Motor, Phase B ⁻ :	Motor D	
Miscellaneous	~Enable	FaultOut

These connections apply to bipolar motors. If connecting to unipolar motors do not connect the center tap.

In this configuration the external controller generally consists of a PMD Magellan Motion Processor, a programmable microprocessor or DSP-type device, or a FPGA (field programmable gate array). The external controller provides a continuous stream of position commands or individual phase torque output commands to control the motor position.

3.10 Heat Sink Grounding

The heat sink may be left ungrounded or may be connected to chassis ground for best EMI protection. The heat sink should not be connected to the Atlas Pwr_Gnd.

3.11 Atlas Conversion Factors

The following table provides electrical conversion factors for the various Atlas units. These factors convert Atlas command values specified via the Atlas unit's digital SPI interface (referred to as counts) to physical quantities such as amperage or volts, and vice versa. For more information on the Atlas functions related to these conversion factors see [Chapter 4, Operation](#).

Unit	All Low Power Atlas	All Medium Power Atlas	All High Power Atlas	Example Usage
Amps	.231 mA/count	.763 mA/count	1.526 mA/count	To command a torque of 3.5A to the high power Atlas a value of 3,500mA/1.526mA/count = 2,294 counts is specified.
Volts	1.361 mV/count	1.361 mV/count	1.361 mV/count	A command request to read the Atlas unit's DC Bus voltage gives a value of 12,345. This corresponds to a voltage of 12,345 counts * 1.361 mV/count = 16.8 volts.
Temperature	.0039°C/count	.0039°C/count	.0039°C/count	A command request to read the Atlas unit's internal temperature gives a value of 7,890. This corresponds to a temperature of 7,890 counts * .0039°C/count = 30.8°C.
Foldback Energy	.0059 A ² sec/count	.064 A ² sec/count	.256 A ² sec/count	To command a foldback energy of 50A ² sec to the high power Atlas a value of 50A ² sec/.256 A ² sec/count = 195 counts is specified.

3.11.1 Atlas Settings Defaults and Limits

The following table provides default and limit values for all Atlas units.

Quantity	All Low Power Atlas	All Medium Power Atlas	All High Power Atlas
Overtemperature			
Overtemperature Limit	Default: 75.0°C Low Limit: 0 High Limit: 75.0°C	Default: 75.0°C Low Limit: 0 High Limit: 75.0°C	Default: 75.0°C Low Limit: 0 High Limit: 75.0°C
Overtemperature Hysteresis	Default: 5.0°C Low Limit: 0 High Limit: 25.0°C	Default: 5.0°C Low Limit: 0 High Limit: 25.0°C	Default: 5.0°C Low Limit: 0 High Limit: 25.0°C
Voltage			
Overvoltage Limit	Default: 52.0 V Low Limit: 10.0 V High Limit: 52.0 V	Default: 52.0 V Low Limit: 10.0 V High Limit: 52.0 V	Default: 60.0 V Low Limit: 10.0 V High Limit: 60.0 V
Undervoltage Limit	Default: 10.0 V Low Limit: 10.0 V High Limit: 48.0 V	Default: 10.0 V Low Limit: 10.0 V High Limit: 48.0 V	Default: 10.0 V Low Limit: 10.0 V High Limit: 56.0 V

Quantity	All Low Power Atlas	All Medium Power Atlas	All High Power Atlas
Current Foldback			
Continuous Current Limit, Brushless DC Motor	Default: 2.12 A	Default: 7.07 A	Default: 14.1 A
	Low Limit: 0.0 A	Low Limit: 0.0 A	Low Limit: 0.0 A
	High Limit: 2.12 A	High Limit: 7.07 A	High Limit: 14.1 A
Continuous Current Limit, DC Brush Motor	Default: 1.50 A	Default: 7.00 A	Default: 14.0 A
	Low Limit: 0.0 A	Low Limit: 0.0 A	Low Limit: 0.0 A
	High Limit: 1.50 A	High Limit: 7.00 A	High Limit: 14.0 A
Continuous Current Limit, Step Motor	Default: 2.12 A	Default: 6.36 A	Default: 12.7 A
	Low Limit: 0.0 A	Low Limit: 0.0 A	Low Limit: 0.0 A
	High Limit: 2.12 A	High Limit: 6.36 A	High Limit: 12.7 A
Energy Limit, Brushless DC Motor	Default: 2.95 A ² sec	Default: 31.9 A ² sec	Default: 127.5 A ² sec
	Low Limit: 0.0 A ² sec	Low Limit: 0.0 A ² sec	Low Limit: 0.0 A ² sec
	High Limit: 2.95 A ² sec	High Limit: 31.9 A ² sec	High Limit: 127.5 A ² sec
Energy Limit, DC Brush Motor	Default: 3.63 A ² sec	Default: 32.2 A ² sec	Default: 128.7 A ² sec
	Low Limit: 0.0 A ² sec	Low Limit: 0.0 A ² sec	Low Limit: 0.0 A ² sec
	High Limit: 3.63 A ² sec	High Limit: 32.2 A ² sec	High Limit: 128.7 A ² sec
Energy Limit, Step Motor	Default: 2.95 A ² sec	Default: 34.7 A ² sec	Default: 138.9 A ² sec
	Low Limit: 0.0 A ² sec	Low Limit: 0.0 A ² sec	Low Limit: 0.0 A ² sec
	High Limit: 2.95 A ² sec	High Limit: 34.7 A ² sec	High Limit: 138.9 A ² sec

For more information on Atlas overtemperature safety functions see [Section 4.7.2, "Overtemperature Fault."](#)

For more information on Atlas overvoltage and undervoltage safety functions see [Section 4.7.4, "Undervoltage Fault."](#)

For more information on Atlas Current Foldback safety functions see [Section 4.7.9, "Current Foldback."](#)

4. Operation

In This Chapter

- ▶ Functional Overview
- ▶ Internal Block Diagram
- ▶ Commutation
- ▶ Current Loop
- ▶ Power Stage
- ▶ Status Registers
- ▶ Safety Processing Functions
- ▶ Step Motor Control
- ▶ User Memory Space & Buffers
- ▶ Trace Capture
- ▶ Power-up & Non-Volatile Initialization Storage
- ▶ SPI Communications Overview

4.1 Functional Overview

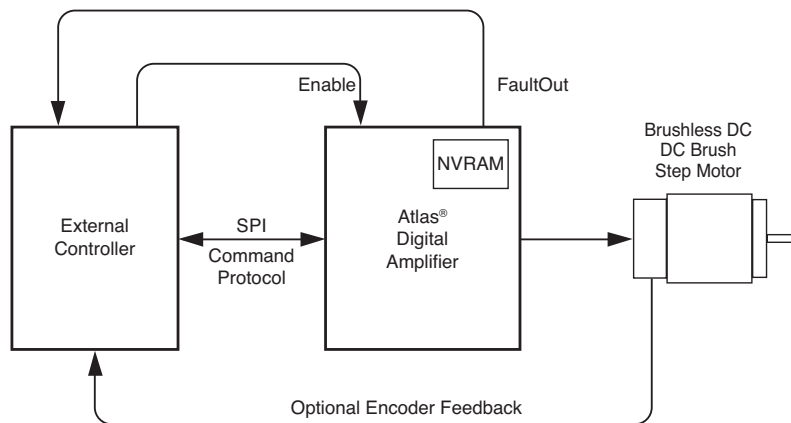

Figure 4-1: High Level System Diagram

Atlas Digital Amplifiers are single-axis devices for torque or voltage-mode control of three-phase brushless DC motors, DC Brush motors, or two-phase step motors. They accept a stream of desired torque or voltage values from an external controller and perform all current loop processing and switching bridge control to continuously drive the motor coils to the specified, commanded values.

In addition to providing a stream of torque or voltage commands, the external controller is used to set up operational parameters needed by Atlas such as control gains, safety-related parameters, and other information. These parameters may be provided to Atlas at each power up, or stored non-volatily in Atlas so that they no longer need to be loaded at each power-up. See [Section 4.11, “Power-Up & Non-Volatile Initialization Storage”](#) for more information.

Communication to/from Atlas occurs via an SPI interface and associated protocol that uses packet-oriented commands to specify various Atlas parameters, and, if desired, request status information from Atlas. This protocol has been designed for maximum speed and flexibility so that torque or voltage commands can be continuously sent to Atlas even while the external controller queries Atlas for various information. Please refer to the *Atlas Digital Amplifier Complete Technical Reference* for information on the SPI interface.

When Atlas is used in a higher level system such as a servo-based velocity or position controller, torque commands are typically sent to Atlas continuously, at the motion controller's servo rate. For most systems this rate is in the 1,000 to 10,000 samples per second range. However Atlas may also be used with direct voltage or torque control applications that utilize Atlas to specify a desired output value just once after power-up, or only occasionally as required by the application.

To disable Atlas operations it may be powered down, the *Enable* signal may be de-asserted, or various commands that result in Atlas operations being suspended may be sent by the external controller to Atlas through the SPI interface. In addition, there are several conditions where Atlas automatically shuts down for safety-related reasons. These may include short circuit detection, under and over voltage protection, I^2t current limiting, and amplifier over temperature detection. See [Section 4.7, "Safety Processing Functions"](#) for more information on emergency stop and related functions.

4.2 Internal Block Diagram

Figure 4-2:
Internal Block
Diagram

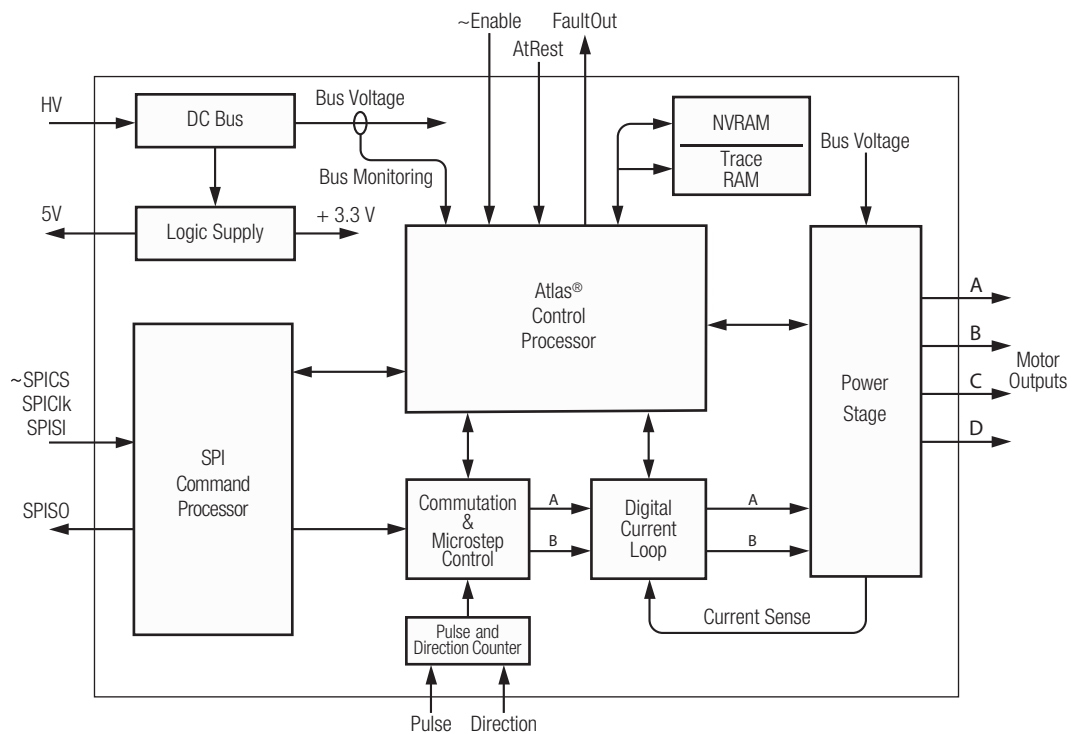

[Figure 4-2](#) shows the internal block diagram of Atlas. Here are summary descriptions of the major modules and functional areas:

Commutation—this module utilizes internally generated information, or information provided by the external controller, to split up the desired overall torque command into individual phase commands to drive Brushless DC and step motors.

Current Loop—this module inputs the desired current for each motor coil and uses the measured current feedback from each motor coil to develop PWM (pulse width modulation) output command values for the power stage. The current loop module may be disabled, in which case Atlas will drive the motor in voltage mode. See [Section 4.4, “Current Loop”](#) for more information on the current loop module.

Power Stage—this module receives desired voltages for each motor coil and manages the Atlas unit’s high performance MOSFET-based switching bridge to precisely drive the coils of the motor. See [Section 4.5, “Power Stage”](#) for a detailed description of this module.

Status Registers—this module holds various status registers including an Event Status Register, a Drive Status register, a Drive Fault Status Register, a signal status, and an SPI Status Register.

Safety Processing—this module manages Atlas unit safety-related functions including the internal temperature sensor, bus voltage error, the *Enable* input signal, current foldback, the *FaultOut* output signal, event action processing, and more.

Step Motor Processing—this module implements step motor-specific features including microstep signal generation, holding current management, and *Pulse*, *Direction*, and *AtRest* signal processing.

Memory Buffers—this module provides user-accessible memory for trace and setup parameter configuration storage.

Trace—this module provides a facility for continuously storing up to four simultaneous Atlas variables in the memory buffers.

Power-up & Non-Volatile Initialization Storage—this module manages the power-up sequence and provides the ability to store selected parameters into the Atlas unit’s non-volatile memory.

SPI Command Processor—This module manages all communications to/from the external controller.

4.3 Commutation

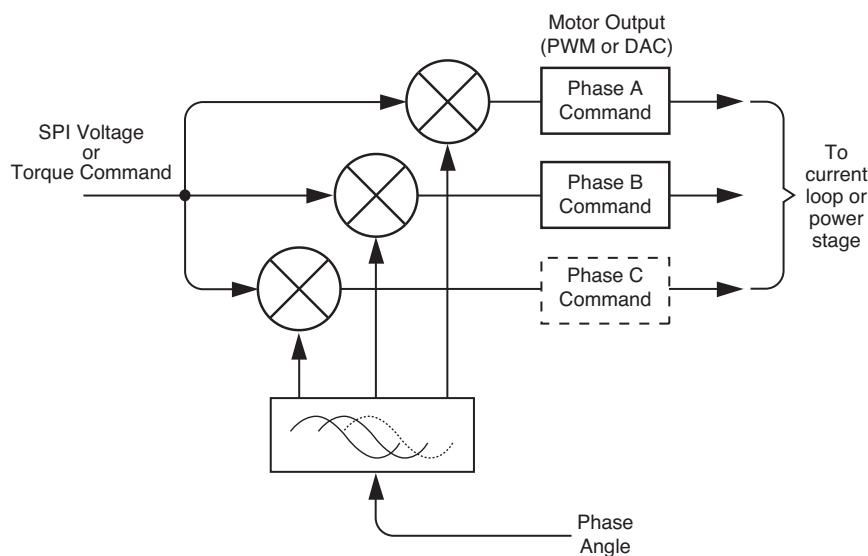

Figure 4-3:
Commutation
Control
Sequence

Brushless DC motors have three phases (generally referred to as A, B, and C) separated from each other by 120 electrical degrees. The process of splitting up the overall torque command into constituent phase commands is called commutation. [Figure 4-3](#) provides an overview of the control sequence when a brushless DC motor is controlled by Atlas.

The first step is that the external controller specifies the desired motor voltage or torque command to the Atlas. This command is then commutated into constituent phase-specific values. This process applies to step motors as well as Brushless DC motors, however for step motors the process is called microstepping. See [Section 4.8, “Step Motor Control”](#) for a detailed discussion of step motor control with Atlas amplifiers. DC Brush motors are single phase devices, and do not require commutation.

Once commutated, the individual commands for the A, B, and C phases are output either directly to the power stage or to the current loop module (depending on whether current control has been requested). If output to the current loop module, additional calculations are performed using the measured current through each winding to determine a final phase command. See [Section 4.4, “Current Loop”](#) for details.

Atlas does not directly accept commutation inputs such as Hall sensors, so phase angle information must be provided by the external controller via the SPI interface. When used with the Magellan Motion Processor all such phase information is provided automatically. When used with other external controllers, for detailed information on how to provide this phase angle information, as well as other details of Atlas commutation operations, refer to the *Atlas Digital Amplifier Complete Technical Reference*.

4.4 Current Loop

Figure 4-4:
Current Loop
Control Flow

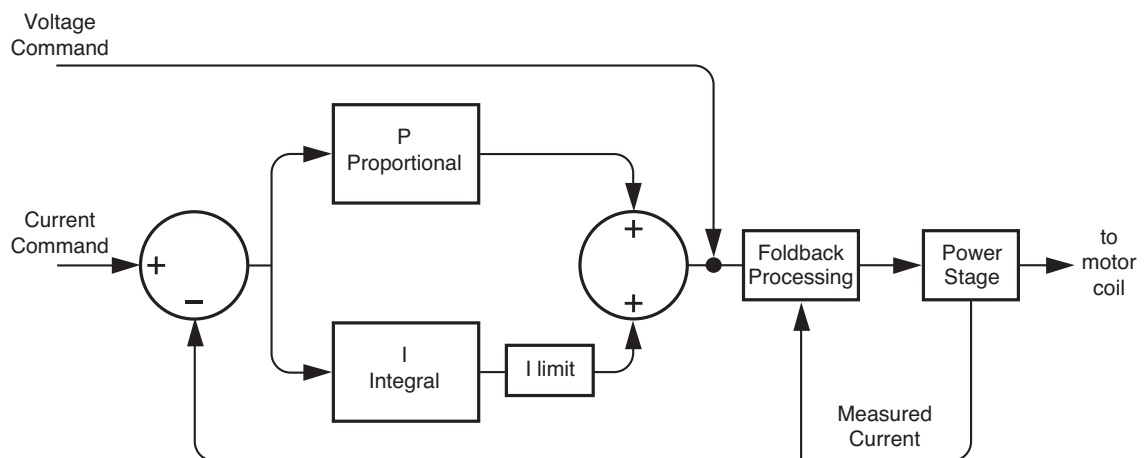

Digital current control is a technique used with DC brush, brushless DC, and step motors for precisely controlling the current through each winding of the motor. By controlling the current, response times are improved and motor efficiency is increased.

[Figure 4-4](#) provides an overview of Atlas unit’s current controller. For single-phase motors such as DC brush, one current loop per axis is used. For brushless DC motors, two current loops are used and the third phase command is derived from the other two phases. When driving step motors, two current loops are used, one for the phase A coil, and one for the phase B coil.

There are three overall methods of current control provided by Atlas, however not all methods are used with all motor types. The first method is individual phase control. The table below summarizes which current control modes are available with the three motor types supported by Atlas, along with the default configuration for that motor type.

Current Control Method	Brushless DC	DC Brush	Step Motor
Individual Phase Control	✓	✓ (default)	✓
Field Oriented Control	✓ (default)		✓ (default)
Third Leg Floating	✓		

The large majority of applications will use FOC to drive Brushless DC or step motors. FOC usually provides the highest top speeds and more energy efficient operation of the motor compared to individual phase control. Third leg floating is an option that should generally only be considered for Hall-commutated motors. In that configuration, third leg floating can sometimes provide a higher top speed than FOC. Finally, individual phase control is always used with DC Brush motors, and may, under certain specialized conditions, provide improved performance for Brushless DC motors over FOC.

If during normal operation the current loop is disabled, then the output from the commutation module will pass directly to the power stage module, with no current control being performed. The most common use of this is to run the amplifier in voltage mode, which may be useful under some conditions for calibration or testing.

The *Atlas Digital Amplifier Complete Technical Reference* provides much more information on the various Atlas current control modes including control flow diagrams and how to set up and read various current control related parameters.

4.5 Power Stage

Atlas contains a high performance MOSFET-based power stage that utilizes one or more switching bridges to drive the motor coils. The use of 3-phase and H-bridge topologies provides full 4-quadrant operation for all motor types. In addition, Atlas uses an advanced PWM switching scheme that minimizes the ripple current on the motor windings while maximizing the current loop performance. The fundamental frequency of the ripple current is twice the PWM frequency, and well out of the audible range in all cases.

The PWM frequency is selectable between 20 kHz, 40kHz, 80kHz, and 120 kHz to cover a broad range of motor inductances.

In addition to the output bridge function, Atlas provides a current measurement function for use by the current loop module as well as by the safety processing module. Two channels of phase current feedback are provided for brushless DC and step motor current loops. For DC Brush motors feedback for one phase is provided.

4.6 Status Registers

In addition to various numerical registers that may be queried by the external controller, there are five bit-oriented status registers.

These status registers conveniently combine a number of separate bit-oriented fields into a single register. These registers are Event Status, Drive Status, Signal Status, SPI Status, and Drive Fault Status Register. The external controller may directly query these four registers, or the contents of these registers may be utilized by other functional portions of Atlas, such as *FaultOut* signal processing. See [Section 4.7.8, “FaultOut Signal”](#) for more information on *FaultOut* processing.

Refer to the *Atlas Digital Amplifier Complete Technical Reference* for a description of these status registers.

4.7 Safety Processing Functions

Atlas provides a number of amplifier control features that automatically detect and manage safety-related conditions. In addition, Atlas can signal when various conditions, safety or otherwise, occur.

The subsequent sections describe these features.

4.7.1 Overcurrent Fault

Atlas supports automatic detection of excessive current output. This fault occurs when the motor, the wiring leading from Atlas, or Atlas unit's power stage becomes short circuited.

An overcurrent fault will cause the current loop and power stage modules to be disabled, thereby halting further motor output. To recover from this condition the user should determine the nature of the fault. It is generally desirable to power down Atlas to check connections or otherwise correct the Atlas-attached hardware so that the problem does not occur again.

If the overcurrent condition has been resolved, when restart is attempted Atlas will resume normal operations. If the overcurrent condition has not been resolved, the overcurrent condition will immediately occur again.



Over current faults are serious conditions and warrant the utmost precaution before re-enabling amplifier operation. It is the responsibility of the user to determine the cause and corrective action of any electrical fault.

4.7.2 Overtemperature Fault

Atlas provides the capability to continually monitor and detect excessive internal temperature conditions. Such a condition may occur if excessive current is requested, if heat sinking of the Atlas unit is inadequate, or if some other problem results in elevated drive temperatures.

To detect this condition a programmable temperature threshold is continuously compared to an internal temperature sensor. If the value read from the internal sensor exceeds the programmed threshold, an overtemperature fault occurs. In addition, a settable overtemperature hysteresis allows the user to ensure that the Atlas temperature drops by a specified number of degrees before allowing drive restart.

See [Section 3.11.1, “Atlas Settings Defaults and Limits”](#) for information on overtemperature-related conversion factors, defaults, and limit settings for each Atlas power level.

An over temperature fault will cause the current loop and power stage modules to be disabled, thereby halting further motor output. To recover from this condition the user should determine the nature of the fault. It is generally desirable to power down Atlas to correct the condition.

If the overtemperature condition has been resolved, when restart is attempted Atlas will resume normal operations. If the overtemperature condition has not been resolved, the condition will immediately occur again.



Overtemperature faults indicate that the internal safe limit of the drive temperature range has been exceeded. This potentially serious condition can result from incorrect motor connections, excessive power demands placed on the Atlas amplifier, or inadequate heat sinking. It is the responsibility of the user to operate Atlas within safe limits.

4.7.3 Overvoltage Fault

Atlas provides the capability to continually monitor and detect excessive voltages on the incoming voltage supply. Such a condition may occur if there is a fault in the system power supply, if a large back EMF (electro motive force) is generated during motor deceleration, or if some other problem results in an elevated bus voltage.

To detect this condition a programmable bus voltage threshold is continuously compared to the bus voltage sensor. If the value read from the internal sensor exceeds the programmed threshold, an overvoltage fault occurs.

See [Section 3.11.1, “Atlas Settings Defaults and Limits”](#) for information on overvoltage-related conversion factors, defaults, and limit settings for each Atlas power level.

An overvoltage fault will cause the current loop and power stage modules to be disabled, thereby halting further motor output. To recover from this condition the user should determine the nature of the fault. In most cases it is desirable to power down Atlas to correct the condition.

If the overvoltage condition has been resolved, when restart is attempted Atlas will resume normal operations. If the overvoltage condition has not been resolved, the condition will immediately occur again.

Overvoltage faults indicate that a serious safety condition has occurred. It is the responsibility of the user to operate Atlas within safe limits.



4.7.4 Undervoltage Fault

Atlas also provides the capability to sense undervoltage conditions. This value is compared to the value read from the drive DC bus, and if the value read is less than the programmed threshold, an undervoltage fault occurs.

All other aspects of this feature are the same as for overvoltage sense. Just as for overvoltage conditions, it is the user's responsibility to determine the seriousness of, and appropriate response to, an undervoltage condition.

4.7.5 Watchdog Timeout

Atlas provides a programmable watchdog timer that can detect an unexpected lack of activity from the external controller. Typically, such a condition is due to an SPI communication problem or an external controller malfunction. Particularly when the external controller is used to provide higher level velocity or position control, a watchdog timeout may therefore represent a very serious condition.

To effect the watchdog function Atlas monitors the amount of time between successive valid SPI torque or voltage commands from the external controller. If the amount of time between commands exceeds the programmed watchdog timer, the watchdog fault is triggered.

A watchdog timeout fault will cause the current loop and power stage modules to be disabled, thereby halting further motor output. To recover from this condition the user should determine the nature of the fault. In most cases it is desirable to power down Atlas to correct the condition.

Watchdog timeout faults indicate that a serious safety condition has occurred. It is the responsibility of the user to operate Atlas within safe limits.



4.7.6 Drive Enable

Atlas supports an *Enable* input signal that must be active for proper amplifier operation. This signal is useful for allowing external hardware to automatically shut Atlas down. The signal has an active low interpretation.

If the Enable signal becomes inactive (goes high) the current loop and power stage modules are disabled, thereby halting further motor output. To recover from this condition the user should determine the nature of the fault. It may be desirable to power down Atlas to correct the condition.

4.7.7 Drive Fault Status Register

To simplify recovery from drive-related faults Atlas provides a Drive Fault Status register. Refer to the *Atlas Digital Amplifier Complete Technical Reference* for more information on this register.

4.7.8 FaultOut Signal

The Atlas unit's *FaultOut* signal is used to indicate an occurrence of one or more drive faults. This signal is active high, meaning it is high when a fault has occurred, and it is low when a fault has not occurred.

The *FaultOut* signal is programmable, so that the user may determine what fault states result in the *FaultOut* signal becoming active. In particular, any bit condition of the Drive Fault Status register may be used to trigger activation of the *FaultOut* signal.

For complete information on *FaultOut* signal programming and the Drive Fault Status register, refer to the *Atlas Digital Amplifier Complete Technical Reference*.

4.7.9 Current Foldback

Current foldback, also known as I^2t foldback, is a general purpose tool to protect the drive output stage or the motor from excessive current.

I^2t current foldback works by integrating, over time, the difference of the square of the actual motor current and the square of a user-settable continuous current limit. When the integrated value reaches a user-settable energy limit, Atlas goes into current foldback. The default response to this event is to cause the current loop and power stage modules to be disabled. However it is also possible to program Atlas to attempt to clamp the maximum current to the continuous current limit value. Note that the Atlas unit's ability to do so depends on a properly functioning current loop.

Atlas will stay in foldback until the integrator returns to zero. This is shown in [Figure 4-5](#).

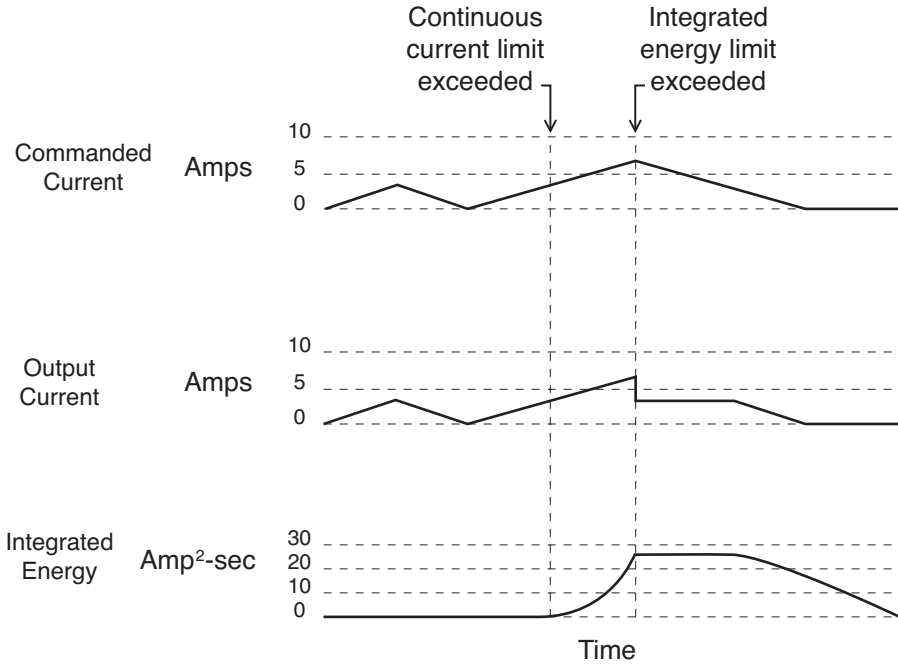

Figure 4-5:
Current
Foldback
Processing
Example

Each Atlas amplifier motor type has particular default and maximum allowed values for both the continuous current limit and energy limit. These values are designed to protect the Atlas from excessive heat generation. See [Section 3.11.1, “Atlas Settings Defaults and Limits”](#) for detailed information on these settings.

Setting continuous current limit and energy limit to less than the maximum supported by the Atlas is useful if the current limit is due to the motor, or to some other factor external to Atlas.

Current foldback, when it occurs, may indicate a serious condition affecting motion stability, smoothness, and performance. It is the responsibility of the user to determine the appropriate response to a current foldback event.



4.8 Step Motor Control

While many aspects of Atlas operation are similar between step motors and Brushless DC or DC Brush motors, Atlas provides a number of special features for supporting step motors. This section describes these special step motor-specific features.

Overall, Atlas provides two step-motor specific position command methods. These are summarized in the table below:

Position Command Mode	Description
Pulse & direction signal input	Atlas directly supports input of hardware <i>Pulse</i> , <i>Direction</i> , and <i>AtRest</i> signals to interface with traditional external controllers that provide these signals. When operated in this mode, SPI communication is not available.
SPI pulse & direction	This pulse & direction interface utilizes the external controller SPI interface to provide continuous position information to Atlas. Compared to pulse & direction signal input, this approach allows full use of the SPI communication interface. Note that this is the standard mode used when a Magellan motion processor serves as the external controller.

4.8.1 Pulse & Direction Signal Input Mode

Figure 4-6:
Pulse and
Direction Signal
Input Mode
Control Flow

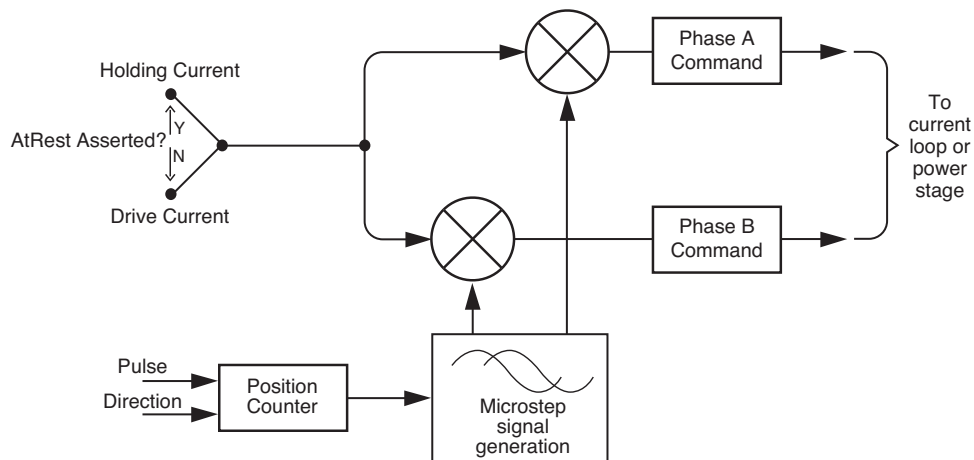

Figure 4-6 shows the control flow of the Atlas when used in pulse & direction signal input mode. The Atlas *Pulse* signal drives a counter which increments or decrements a step motor command position based on the state of the *Direction* signal. Pulse signals are expected to be active low, meaning that a position increment or decrement occurs when this signal transitions from high to low. The *Direction* signal indicates that a pulse received while the *Direction* signal is low is interpreted as a negative direction command, and a pulse received while this signal is high as a positive direction command.

Atlas provides programmable microstepping resolution, which means that the incoming position data stream can be interpreted by the Atlas at various resolutions. The maximum is 256 microsteps per full step, and the default interpretation is 64 microsteps per full step. This means that in the default condition, for a standard 1.8° two-phase stepper, Atlas provides a resolution of 12,800 microsteps per mechanical motor rotation, or roughly .028 degrees of mechanical motion per incoming pulse. Note that this control resolution may not equal the actual system accuracy.

4.8.1.1 Setting the Motor Current

When operating in pulse & direction input mode the current output by Atlas must be specified. Atlas supports two separate, programmable torques. The first is called the drive current and is used during normal step motor operations.

The second is called the holding current and is used when the motor is stationary as indicated by the *AtRest* signal. This signal is typically set when the external controller's trajectory generator completes its move or shortly thereafter. *AtRest* is an active low signal, meaning when no motion is occurring this signal should be set low, and set high when motion is occurring.

4.8.1.2 Pulse & Direction Signal Mode Operation Setup

Because Atlas shares SPI bus signal pins with the *Pulse*, *Direction*, and *AtRest* pins it is not possible to operate the Atlas in the pulse & direction signal input mode while communicating via the SPI communication bus.

To resolve this, Atlas is first connected in SPI mode, and the SPI interface is used to optimize the motion control application during application development and to download desired drive parameters to Atlas unit's non-volatile initialization storage memory. See [Section 4.11, "Power-Up & Non-Volatile Initialization Storage"](#) for more information on non-volatile initialization storage.

Atlas is then switched to pulse & direction signal input mode, and this mode change is stored into non volatile initialization storage memory so that upon the next power up Atlas will operate in pulse & direction signal mode.

For more information on entering and recovering from pulse & direction signal mode, refer to the *Atlas Digital Amplifier Complete Technical Reference*.

4.8.2 Current Control with Step Motors

Current control when driving step motors occurs using either field-oriented control or independent phase control. See [Section 4.4, “Current Loop”](#) for a summary of the Atlas unit’s current loop.

4.9 User Memory Space & Buffers

Start Address (in Hexadecimal)	Function
0X0000 0000	Trace RAM (1,020 words)
0X0000 03FD	Reserved
0X2000 0000	NVRAM (1,024 words)
0X2000 0400	Reserved

Atlas provides the ability to store or retrieve data from an internal user memory space. [Figure 4-7](#) shows the user memory space for Atlas. There is a trace area, and an area that is used to store non-volatile setup commands that can be read back by the external controller. See [Section 4.10, “Trace Capture”](#) for more information on trace. See [Section 4.11, “Power-Up & Non-Volatile Initialization Storage”](#) for more information on Atlas operational configuration storage.

Refer to the *Atlas Digital Amplifier Complete Technical Reference* for a detailed description of the user memory space, Atlas buffer management, and trace functions.

4.10 Trace Capture

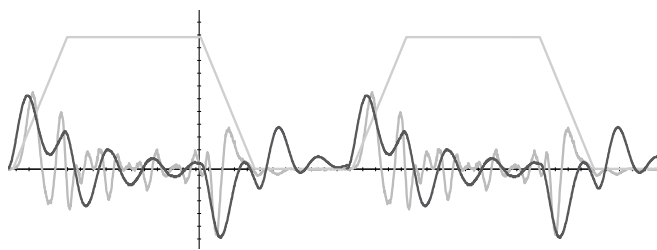

Trace capture is a powerful Atlas feature that allows parameters and registers to be continuously captured and stored to the Atlas units’ trace RAM user memory space. The captured data may later be downloaded by the external controller using standard memory buffer access commands. Data traces are useful for optimizing current loop performance, diagnosing SPI communications, capturing signal data, or assisting with any type of monitoring where a precise time-based record is required.

Broadly speaking, there are three phases associated with data trace operations. In the first phase, the external controller specifies which parameters will be captured, and how the trace will be executed. In the second phase, Atlas captures the trace data. This can occur autonomously, or under external controller control. Finally, in the third phase the external controller retrieves the data. This can occur after the trace is complete, or concurrently with capture.

Figure 4-7:
User Memory
Space and
Buffers

Figure 4-8:
Example
Motion Trace
Capture

For a complete description of trace control options and a list of traceable parameters refer to the *Atlas Digital Amplifier Complete Technical Reference*.

4.11 Power-Up & Non-Volatile Initialization Storage

After receiving stable power at the HV pins Atlas begins its initialization sequence.

In a power-up where no user-provided initialization parameters have been stored this takes approximately 250 mSec. At the end of this sequence all parameters are at their default values, and both the current loop module and the power stage module are disabled. At this point Atlas is ready to receive commands and begin operation.

4.11.1 Power-up with Non-Volatile Initialization Storage

Atlas supports a 1,024 word memory segment that is non-volatile (NVRAM), meaning the data stored will be available even after power to the Atlas is removed.

[Figure 4-7](#) shows the user memory space and the location of the NVRAM segment. The primary purpose of the NVRAM is to allow Atlas configuration information to be stored, so that upon power up it can be automatically loaded rather than requiring an external controller to perform this configuration initialization function.

The configuration information stored in the NVRAM takes the form of Atlas command packets, however rather than being sent via SPI, these packet words are stored in memory. If the non-volatile initialization memory has been loaded with information the power-up sequence detects this and begins executing the commands stored in the non-volatile memory. Note that processing stored commands may increase the overall initialization time depending on the command sequence stored.

If there are errors in the stored command sequence then an instruction error will be set so that the error can later be diagnosed. Atlas will abort initialization if it detects any error while processing commands.

For more information on NVRAM storage and operation refer to the *Atlas Digital Amplifier Complete Technical Reference*.

4.12 SPI Communications Overview

Atlas uses an SPI (Serial Peripheral Interface) digital connection to communicate with the external controller. This connection is used to setup Atlas parameters, specify voltage or torque output values, monitor Atlas operation, as well as other functions.

SPI is a convenient interface because it is available on many microprocessors, provides relatively high speed communications, and uses only 4 signals; SPIClk (Clock), SPICS (chip select), SPISI (slave in), and SPISO (slave out). Atlas utilizes standard SPI signaling and timing control for the hardware interface and implements a higher level protocol on top of this. See [Section 3.6, “AC Characteristics”](#) to learn more about low-level hardware SPI signal timing, voltage levels, etc.

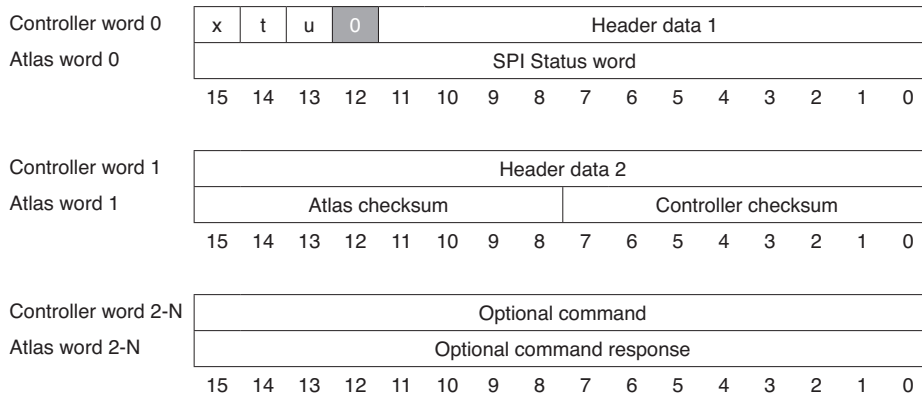

Figure 4-9:
SPI
Communications Protocol
Overview

All communications to and from Atlas are in the form of a packet. [Figure 4-9](#) shows the overall packet format. A falling edge of the chip select begins the packet, and a rising edge of the chip select ends the packet. All Atlas SPI packets are comprised of a two word header and one or more optional command words.

The first two words of the packet are called the header and are used to specify a desired motor voltage or torque along with certain other functions such as when a trace starts and when a command update should occur.

As shown in [Figure 4-9](#) each SPI word sent from the external controller to Atlas results in a return word sent from Atlas to the external controller. In fact at a signal level, each outgoing bit is sent simultaneously with each incoming bit, providing full duplex communications.

The external controller must receive and process data words sent to it by Atlas. These return words, depending on the context, contain transmission integrity information, status bits, or other useful information.

4.12.1 Sending a Voltage or Torque Output Value

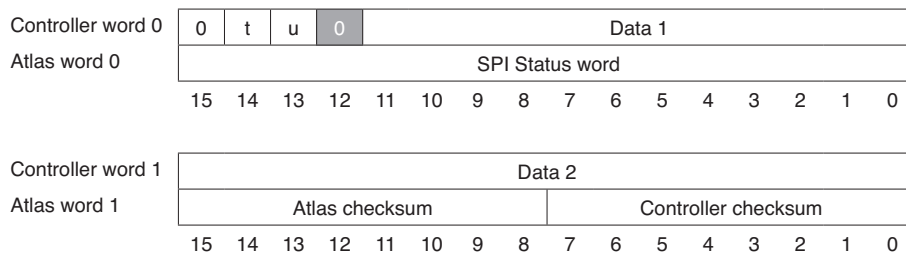

Figure 4-10:
Sending a
Voltage or
Torque Output
Value

Generally the most frequently used header transaction is an instantaneous voltage or torque output request for output by the drive. If Atlas is used as part of a higher level velocity or position controller, then these values are continuously sent to Atlas at the servo sampling speed of the main motion controller, typically between 1 kHz and 10 kHz.

[Figure 4-10](#) shows the overall format of the header words when voltage or torque commands are being sent. Depending on the motor type and command mode being used the data words will be loaded one of several different ways.

For a complete description of these fields, along with many other details of Atlas SPI operation, refer to the *Atlas Digital Amplifier Complete Technical Reference*.

This page intentionally left blank.

A. Atlas Developer Kits

A

In This Appendix

- ▶ Overview
- ▶ Developer Kit P/Ns
- ▶ Installation and Getting Started
- ▶ Atlas BK Board Reference Information
- ▶ L-Bracket

A.1 Overview

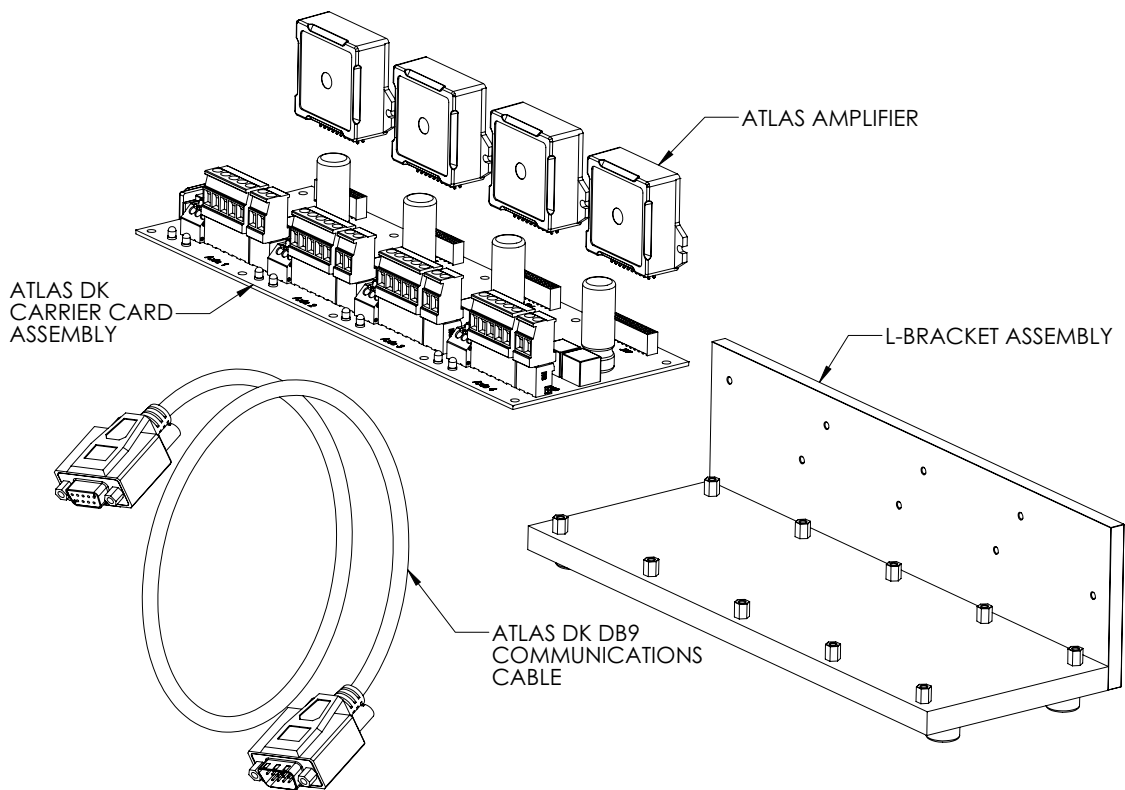

Figure A-1:
Developer Kit
Components
(four-axis
version shown)

To simplify development with Atlas Amplifiers several developer kits (DKs) are available.

The major elements of these DKs are:

- Atlas DK board (comes in 1 or 4 axis version)
- Atlas DK DB9 communications cable

- Base plate and, if vertical Atlas DKs are ordered, vertical plate forming an L-bracket for heat sink attachment with associated mounting hardware (comes in 1 or 4 axis version)
- Compact to ultra-compact size Atlas converter cards.
- For horizontal DKs heat sinks with adhesive thermal pads
- Various other assembly components such as screws and allen keys depending on the Atlas DK type ordered

A.2 Developer Kit P/Ns

There are four available Atlas developer kits, reflecting a choice of one or four axis board, and a choice of two different Atlas mounting configurations; vertical and horizontal. The following table shows this:

Developer Kit P/N	# of Axes	Atlas Type
MDK1LI0000V	1	Vertical
MDK1LI0000H	1	Horizontal
MDK4LI0000V	4	Vertical
MDK4LI0000H	4	Horizontal

[Figure A-1](#) shows an overview of an Atlas Developer Kit assembly. The particular assembly shown is for a four axis vertical DK, but the overall elements are similar for one axis developer kits. Horizontal developer kits are also similar except that there is no vertical plate included. Note that the Atlas units shown in the figure are not included with the developer kit and must be purchased separately.



Atlas Developer Kits consists of the mounting and connection hardware only. To create a complete functioning setup one or more Atlas Amplifier units must be ordered separately and then installed onto the DK hardware.

A.3 Installation and Getting Started

In these instructions it is assumed that you have purchased one of the Magellan Developer Kits, which come with the Pro-Motion exerciser and tuning software. If you have not purchased a Magellan DK then you will still find these instructions useful, however you will use the detailed connections detailed in [Section A.4, “Atlas DK Board Reference Information.”](#) to connect your system and begin operation.

A.3.1 Developer Kit Assembly

The first step in getting started with your Atlas Developer Kit is mechanically assembling the hardware that comes with the DK to the Atlas units ordered. This will be described in detail in the next several sections.



It is good practice to wear a grounding strap while handling both the machine controller board and the Atlas units. In addition it is recommended that assembly be undertaken on a surface that dissipates electrostatic charge.

A.3.2 Vertical Atlas Developer Kit Assembly

A.3.2.1 Thermal Pad Attachment

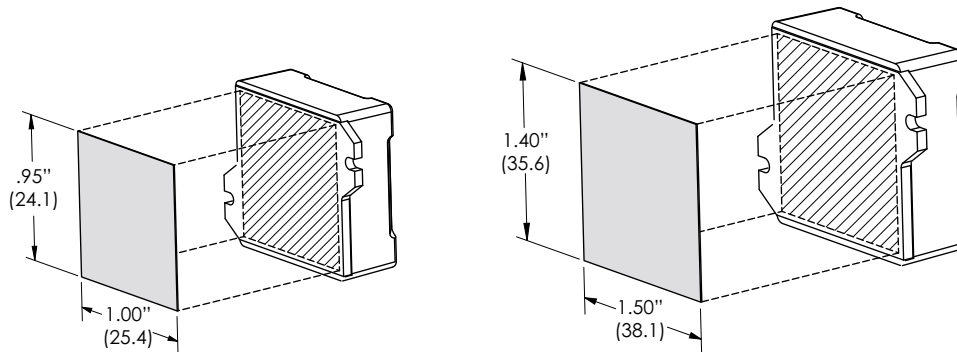

Figure A-2:
Thermal
Transfer
Material
Attachment

It is very important to have good thermal contact between the Atlas units and the L-bracket heat sink. Therefore the first step will be to attach thermal pads to each vertical Atlas unit to be installed. Horizontal Atlas units do not use a vertical plate for heat sinking and therefore are described in a different section [Section A.3.3, “Horizontal Atlas Developer Kit Assembly.”](#)

Locate the thermal pads of matching size. Two sets of thermal pads are included in your developer kit reflecting the two available Atlas package sizes - compact or ultra-compact. As shown in the figure above compact units use the larger thermal pad and ultra compact units use the smaller thermal pad.

Next, carefully remove the thin plastic protective sheets on either side of each pre-cut thermal pad and mount onto the Atlas unit, carefully aligning the pads with the Atlas’ metallic backing, and applying finger pressure to adhere the pads to the metal. Note that the dimensions of each pad are not exactly square, so it is best to align the pads in the orientation shown in the diagram. Once pressed in place the pads should stay in place, but if required the pads can be removed and remounted.

A.3.2.2 Installing Atlas Units into the Board

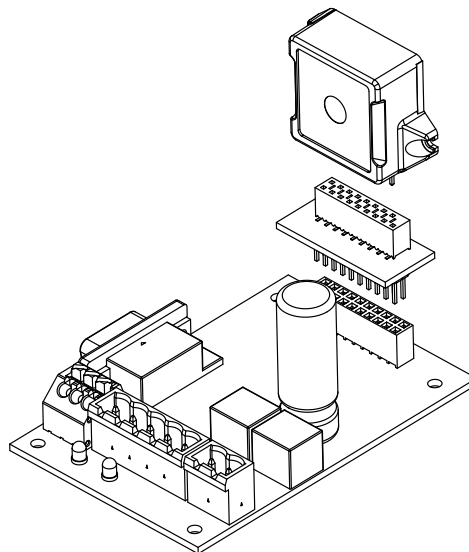

Figure A-3:
Vertical Atlas
Installation into
DK Board

To install vertical Atlas units into the Atlas DK board sockets, confirm that the Atlas is oriented correctly, with the metal heat sink surface facing toward the vertical L-bracket plate. Carefully align the Atlas pins to the socket and press firmly down until the Atlas is fully seated in the socket.

With the four axis DK board, if using Atlas units for specific motor types, the motor type of the Atlas should conform to the motor type that will be utilized for that axis. For example if your system has a DC brush motor at axis #1, and a step motor connected at axis #2, you should install a DC brush motor Atlas in the axis #1 socket, and a step motor Atlas in the axis #2 socket.



Extreme care should be taken when installing the Atlas into its socket. Failure to orient the Atlas correctly, or mis-alignment of pins may result in damage to the Atlas units.

Note that compact Atlas units which are the larger of the two sizes, plug directly into the DK board and do not require the converter card shown in [Figure A-3](#). The smaller ultra compact units, which are the package sizes for the low and medium power Atlas units, require the installation of a conversion card before installation into the Atlas DK.

For any ultra compact Atlas units to be installed onto the board, first mate each ultra-compact Atlas unit to a converter card. Before connecting the Atlas to the converter card, care should be taken to insure that they are oriented correctly, and that all pins align correctly without overhang. Once the ultra-compact Atlas has been properly mated to the converter card, the converter/Atlas assembly can then be inserted into the DK board.

Note that for the four axis Atlas DK board the socket installation location of the compact and ultra compact Atlas units is interchangeable. There is no restriction on the location of compact Atlas units versus the location of ultra compact Atlas units.

A.3.2.3 Attaching Atlas Units to the Vertical Plate

Figure A-4:
Attaching Atlas
Units to
Vertical Plate

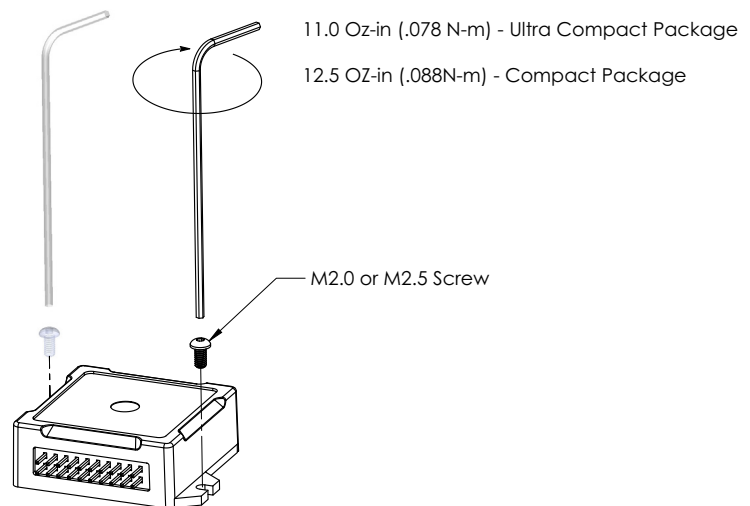

Finally, vertical Atlas units should be fastened to the vertical plate. Two screws are used to attach each Atlas and [Figure A-4](#) shows how the screws connect to the vertical plate. For compact Atlas units (high power) the M2.5 screws are used, and for ultra compact Atlas units (low and medium power) M2 screws are used.

Note that the mounting tap hole locations in the vertical plate are different for the compact and ultra compact Atlas units. Use only modest force in attached Atlas units to the vertical plate. [Figure A-4](#) shows this, also providing the torque limit specification for both Atlas types.

Congratulations! You have now completed mechanical assembly of the L-brackets to the Atlas DK board and Atlas units.

A.3.3 Horizontal Atlas Developer Kit Assembly

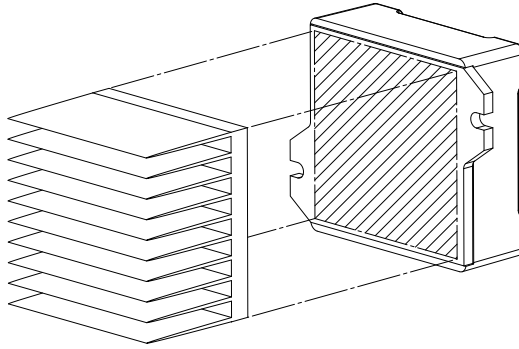

Figure A-5:
Horizontal
Atlas Units and
Heat Sink

Horizontal Atlas units and their corresponding Atlas DK boards do not utilize a vertical plate for heat sinking. Rather, as shown in [Figure A-5](#), they use a special finned heat sink included with the DK materials. Before installing the horizontal Atlas units into the Atlas DK board these heat sinks must be attached to each Atlas unit.

To accomplish this, locate the heat sinks of matching size. Two sets of heat sinks are included in your developer kit reflecting the two available Atlas package sizes - compact or ultra-compact. Next, carefully remove the thin plastic protective sheet on the flat side of the heat sink to be attached. Finally, mount the heat sink onto the Atlas unit, carefully aligning the adhesive surface with the Atlas unit's metallic backing, and applying finger pressure to adhere.

Note that the Atlas metal plate dimensions are slightly larger than the dimensions of the heat sink. The exact location of the heat sink relative to the Atlas metal plate is not critical, but it is best to center the heat sink on the Atlas metal plate as much as possible.

A.3.3.1 Installing Atlas Units into the Board

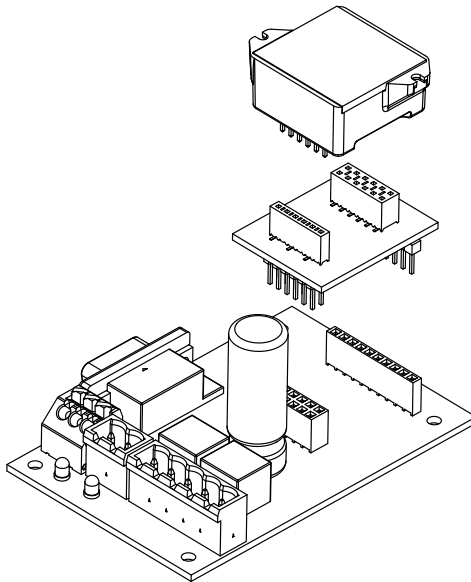

Figure A-6:
Horizontal
Atlas
Installation into
DK Board

As shown in [Figure A-6](#) horizontal Atlas units are inserted into the horizontal DK boards. The footprint of the horizontal units is quite different than the vertical Atlas units, but otherwise the procedure is similar and is described in [Section A.3.2.2, “Installing Atlas Units into the Board.”](#)

Similarly for ultra compact horizontal Atlas units, you must install the converter card before installing the Atlas unit(s) into the DK board, however in this case the horizontal converted card, included with horizontal Atlas DKs, is used rather than the vertical converter card.

Once the Atlas units are installed into the DK board assembly of the horizontal DK is complete.

A.3.4 SPI Bus Connection

Now that your developer kit is assembled you are ready to connect it to your PC and motion system hardware.

You should plug in the provided 12" DB9 cable at the DB9 connection of the DK board. Once you have plugged in the DB9 cable, you can skip forward to [Section A.3.5, "Motor Connections,"](#) and continue from there.



The DB9 connections used with the Atlas DK are not compatible with standard RS232 serial ports. Do not attempt to plug this connector directly into your PC.



The SPI bus is not designed to operate external modules by cable connection, and therefore in production applications it is recommended that Atlas units be located on the same printed circuit card. Regardless of where Atlas is located, it is the responsibility of the user to ensure that SPI signals are noise free and within Atlas unit's timing specifications.

**Figure A-7:
Connecting
DB9 Cable to
DK Board**

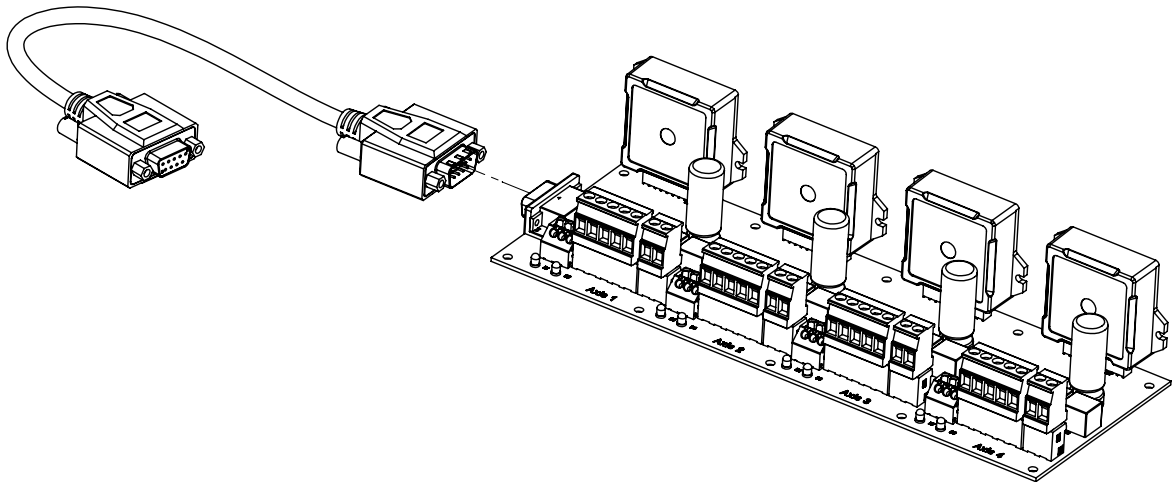

A.3.5 Motor Connections

Refer to [Figure A-8](#) for detailed information on connector placement. For each Atlas, connect the motor using the chart below and the correct axis-specific 6-terminal jack screw plug on the DK board, either J2, J5, J8, or J11 for axis 1, 2, 3, or 4 respectively. Use copper wire gauge 14AWG or larger to ensure that all current output requirements can be met.

If you are using a one axis Atlas DK for motor connections and all other connections described in subsequent sections, refer to the description for axis numbers.

Motor Type	Use Motor Connections	Jackscrew Plug Labels
Brushless DC	Motor A, Motor B, Motor C	Mtr A, Mtr B, Mtr C
DC Brush	Motor A, Motor B	Mtr A, Mtr B
Step Motor	phase A: Motor A, Motor B phase B: Motor C, Motor D	Mtr A, Mtr B, Mtr C, Mtr D

A.3.6 Power Connections

For each Atlas, connect the bus supply voltage (HV) and the associated return ground signal at the correct axis-specific jack screw plug, either J1, J4, J7, or J10 for axis 1, 2, 3, or 4 respectively. Once again, utilize AWG 14 or larger to ensure that full current demand can be met while operating the unit. The power signals are labeled +HV and GND.

For most installations you will use a single, common power supply to power all Atlas units. However this is not required. If desired, you can operate different Atlas units at different voltages by connecting to different DC supplies.

While connecting power signals make sure that the power supply is off.



A.3.7 Enable Signal Connection

You must provide an 'active' enable signal to allow Atlas to operate. There are a few options to accomplish this depending on how you plan to operate your system. A simple approach is to use a short piece of AWG 20 or larger wire to connect the GND connection on the spring clamp Phoenix connector to the Enable input (labeled ~Enab), either J3, J6, J9, or J12 for axis 1, 2, 3, or 4 respectively.

For safety reasons, you may prefer to wire the enable input into a separate switch or E-stop button. Regardless of how it is accomplished, the enable signal must be driven active (low) for Atlas to operate.

A.3.8 Installing and Connecting to the Magellan DK Card

To set up and install the Magellan DK card refer to the Magellan Developer's Kit product that you are using. This manual will help you select jumper settings and make connections to the motor's encoders and other connections. Connect the Atlas DK's SPI bus cable to the appropriate Magellan DK card connector.

Once all connections have been made you should power up the PC (but not the Atlas units) and follow the manual's direction for installing Pro-Motion software. You can run Pro-Motion, check for encoder feedback, etc.... but for axes that utilize Atlas amplifiers, motor output will not yet be operational.

A.3.9 Powering Up the Atlas Units

Once all connections are made and Pro-Motion is installed and running you are ready to provide power to the Atlas units.

Upon doing so verify that there is no motor movement, all power LEDs are lit, and none of the fault out LED indicators are lit. If any of these conditions are not true, power the Atlas units down and recheck connections.

Once a normal power-up is achieved the Atlas units are ready for operation. You may now use Pro-Motion's Axis Wizard to install and operate your motors, or perform direct manual operations using Pro-Motion's various control menus.

Congratulations! You have successfully installed the Atlas DK.

A.4 Atlas DK Board Reference Information

The following sections provides detailed information on the electrical characteristics of the Atlas DK boards.

There are four different designs of DK board, representing vertical and horizontal Atlas mount options in both a one axis and four axis configuration.

Figure A-8:
Component
Placement of
Vertical and
Horizontal DK
DK Boards
(four-axis
version shown)

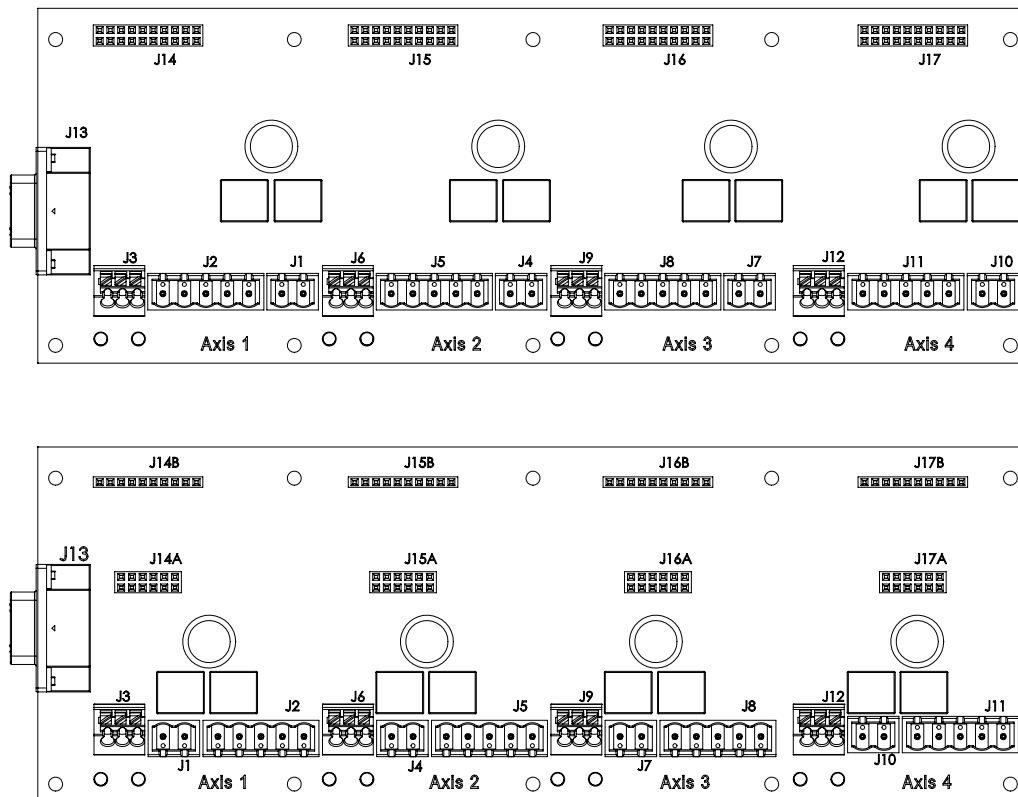

The following descriptions apply for the 4-axis DK boards, however the one-axis are similar, only missing axes 2-4.

A.4.1 J2, J5, J8, and J11 Motor Connectors

J2, J5, J8, and J11 provide jack screw-style connections to the Atlas motor signals.

J2, J5, J8 or J11 Connector		
DK Board Label	Name	Description
Mtr D	Motor D	D Motor connection
Mtr C	Motor C	C Motor connection
Mtr B	Motor B	B Motor connection
Mtr A	Motor A	A Motor connection.
GND	Mtr_Gnd	Ground return for Motor and HV

A.4.2 J1, J4, J7, J10 Power Connectors

J1, J4, J7, and J10 provide jack screw-style connections to supply the Atlas power signals.

J1, J4, J7 and J10 Connectors		
DK Board Label	Name	Description
HV	HV	Motor Supply Voltage
Pwr_Gnd	Pwr_Gnd	Ground return for Motor Supply

A.4.3 J3, J6, J9, J12 Signal Connectors

J3, J6, J9, and J12 provide jack screw-style connections to supply the Atlas signal connections.

J3, J6, J9 and J12 Connectors		
DK Board Label	Name	Description
~Enab	Enable	Enable input
Flt	FaultOut	FaultOut output
GND	GND	Ground return for <i>Enable</i> and <i>FaultOut</i> signals

A.4.4 Quick Connect Motor Type Chart

Motor Type	Connections
Brushless DC	Motor A, Motor B, Motor C
DC Brush	Motor A, Motor B
Step Motor	phase A: Motor A, Motor B phase B: Motor C, Motor D

A.4.5 J13 DB9 Connector

A.4.5.1 SPI Communications

J13 is used to provide SPI communications between the Atlas DK card and a Magellan DK card or the user's motion control system.

Here are the pinouts for J13 when used for SPI communications

J13 Connector		
Pin	Name	Description
1	~SPICS3	SPI chip select for Atlas #3
2	~SPICS2	SPI chip select for Atlas #2
3	Shield	Cable shield connection
4	GND	Ground
5	SPISO	SPI Slave Out
6	~SPICS1	SPI chip select for Atlas #1
7	~SPICS4	SPI chip select for Atlas #4
8	SPIClk	SPI Clock
9	SPISI	SPI Slave In

A.4.5.2 Pulse & Direction Mode

J13 can also be used to provide pulse & direction signals to a single Atlas.

Here are the pinouts for J13 when used in pulse & direction signal mode

J13 Connector		
Pin	Name	Description
1	not used	
2	not used	
3	Shield	Cable shield connection
4	GND	Ground
5	not used	
6	AtRest	Pulse & direction mode <i>AtRest</i> signal
7	not used	
8	Pulse	Pulse & direction mode <i>Pulse</i> signal
9	Direction	Pulse & direction mode <i>Direction</i> signal

A.4.6 Atlas Connections

The DK board connects to the Atlas units via sockets at J14, J15, J16, and J17. The tables below show the Atlas connections for these connectors

A.4.6.1 Vertical Unit Connections

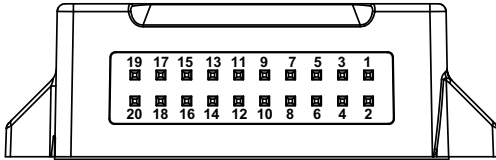

Figure A-9:
Vertical Unit
Pinouts

J14, J15, J16, & J17 Connectors

Pin	Name	Pin	Name
1	Pwr_Gnd	2	Pwr_Gnd
3	HV	4	HV
5	Motor A	6	Motor A
7	Motor B	8	Motor B
9	Motor C	10	Motor C
11	Motor D	12	Motor D
13	~Enable	14	FaultOut
15	5V	16	GND
17	~SPICS/AtRest	18	SPIS/Direction
19	SPIClk/Pulse	20	SPISO

Refer to [Figure A-8](#) for connector locations.

The pins are 0.1 inch spacing and 0.025 inch pin width.



A.4.6.2 Horizontal Unit Connections

Figure A-10:
Horizontal Unit
Pinouts

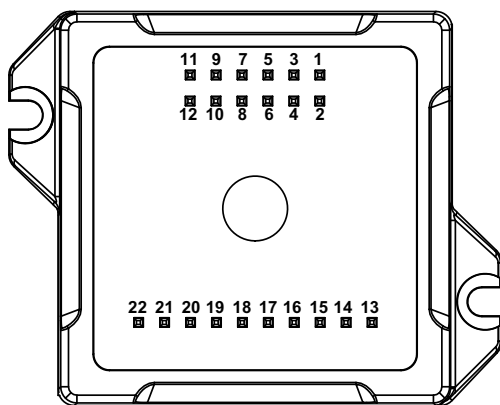

J14A, J15A, J16A, & J17A Connectors

Pin	Name	Pin	Name
1	Motor D	2	Motor D
3	Motor C	4	Motor C
5	Motor B	6	Motor B
7	Motor A	8	Motor A
9	HV	10	HV
11	Pwr_Gnd	12	Pwr_Gnd

J14B, J15B, J16B, & J17B Connectors

13	5V	14	GND
15	~Enable	16	FaultOut
17	GND	18	~SPICS/AtRest
19	SPISO	20	SPIS/Direction
21	SPIClk/Pulse	22	GND



The pins are 0.1 inch spacing and 0.025 inch pin width.

A.4.7 Compact to Ultra Compact Package Signal Converters

When ultra compact package Atlas units are installed in the Atlas DK, signal converter cards are installed between the DK boards and the Atlas unit. Two converter formats are provided, one for horizontal Atlas units and one for Vertical units. These devices convert signals from the DK card's compact package format to the ultra compact format. These converters may also be used in other products designed for the compact package format such as the Prodigy/CME Machine Controller cards.

A.4.7.1 Vertical Ultra Compact Converter Pinouts

The following section shows the connections provided by the vertical converter.

Compact Package Pin	Ultra Compact Package Pin	Name
1, 2	4	Pwr_Gnd
3, 4	1	HV
5, 6	3	Motor A
7, 8	6	Motor B
9, 10	5	Motor C
11, 12	7	Motor D
13	11	~Enable
14	12	FaultOut
15	14	5V
16	13	GND
17	16	~SPICS/AtRest
18	18	SPIS/Direction
19	17	SPIClk/Pulse
20	15	SPISO

A.4.7.2 Horizontal Ultra Compact Converter Pinouts

The following section shows the connections provided by the horizontal converter.

Compact Package Pin	Ultra Compact Package Pin	Name
1, 2	1	Motor D
3, 4	2	Motor C
5, 6	3	Motor B
7, 8	4	Motor A
9, 10	5	HV
11, 12	6	Pwr_Gnd
13	11	5V
14	12, 15	GND
15	14	~Enable
16	13	FaultOut
17	12, 15	GND
18	10	~SPICS/AtRest
19	9	SPISO
20	7	SPIS/Direction
21	8	SPIClk/Pulse
22	12, 15	GND

A.4.8 LED Indicators

The Atlas DK board has two LEDs. The green LED, when lit, indicates that Atlas is receiving valid power input power at HV. The red LED, when lit, indicates that an Atlas FaultOut condition is active.

A.5 L-Bracket

The Atlas DK comes with mounting plates that provide extra mechanical stability and heat sinking during prototyping. Depending on the type of Atlas that you are using, you will use just the base plate or the base plate and vertical plate in the “L” configuration.

L-bracket hardware is provided in the one axis configuration and four axis configuration.

Normally, the DK boards are fully assembled into the base plate. If for whatever reason you need to disassemble or assemble the base plate to the DK board however, you can assemble these components yourself. To assist with this, an assembly drawing is shown in [Figure A-11](#). In addition, you will need 1.5 mm and 2 mm hex wrenches to assemble the DK board, Atlas units, and L-bracket together.

Figure A-11:
Mounting Atlas
to L-bracket
Plates (four-
axis, vertical
version shown)

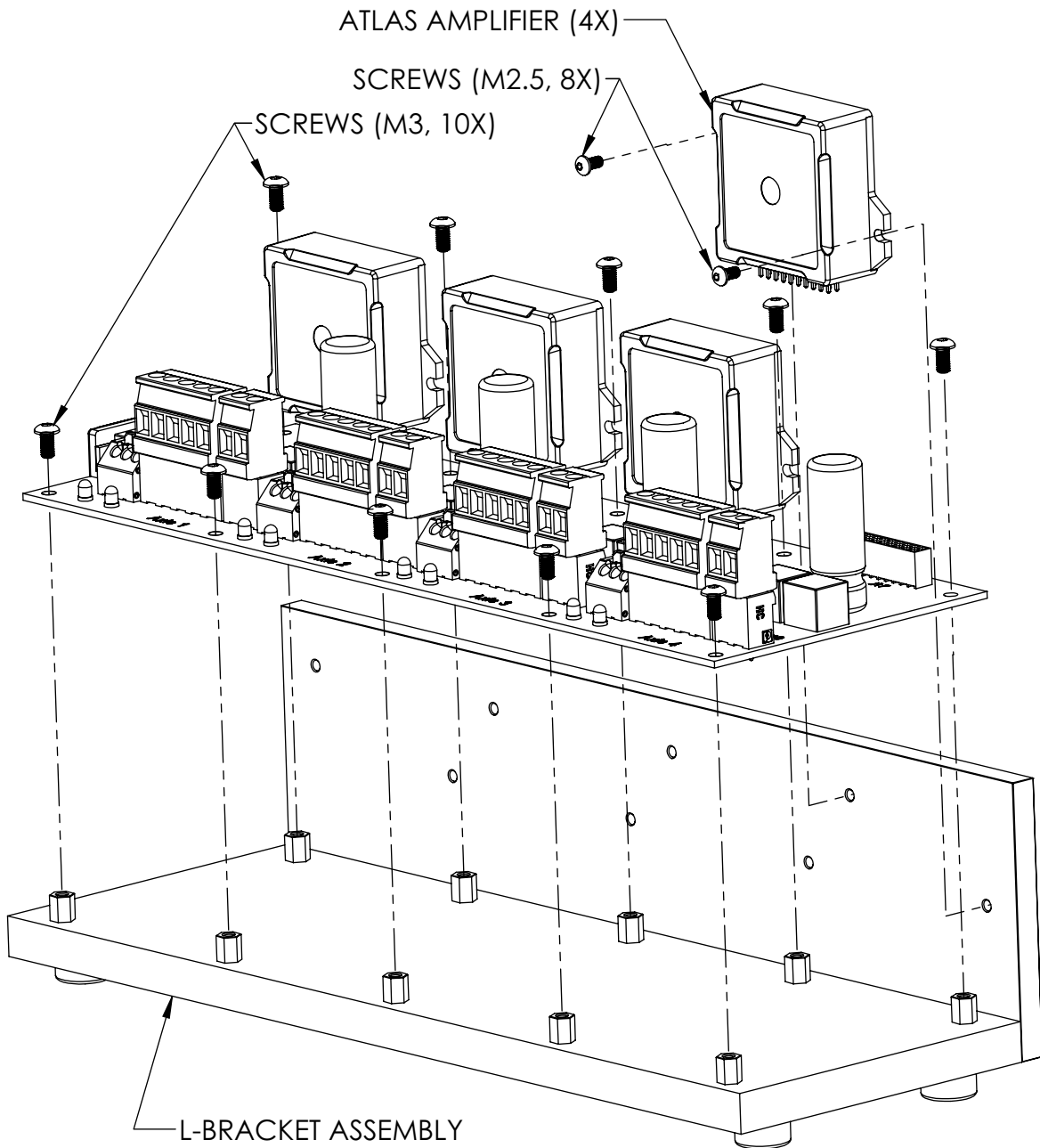

A.5.1 Mounting L-bracket to Other Hardware

To maximize heat sinking capacity you may choose to mount the vertical L-bracket piece to your own hardware. For best thermal performance, a material such as Sil-Pad thermal grease or phase change material should be utilized between metal interfacing layers.

To connect to the vertical plate use four (4) M4 screws threaded into the provided threaded holes in the vertical plate or use four (4) M3 screws with nuts and washers to fasten through from the front.

The diagrams below show the location of these mounting holes for both the 4-axis and 1-axis vertical plates.

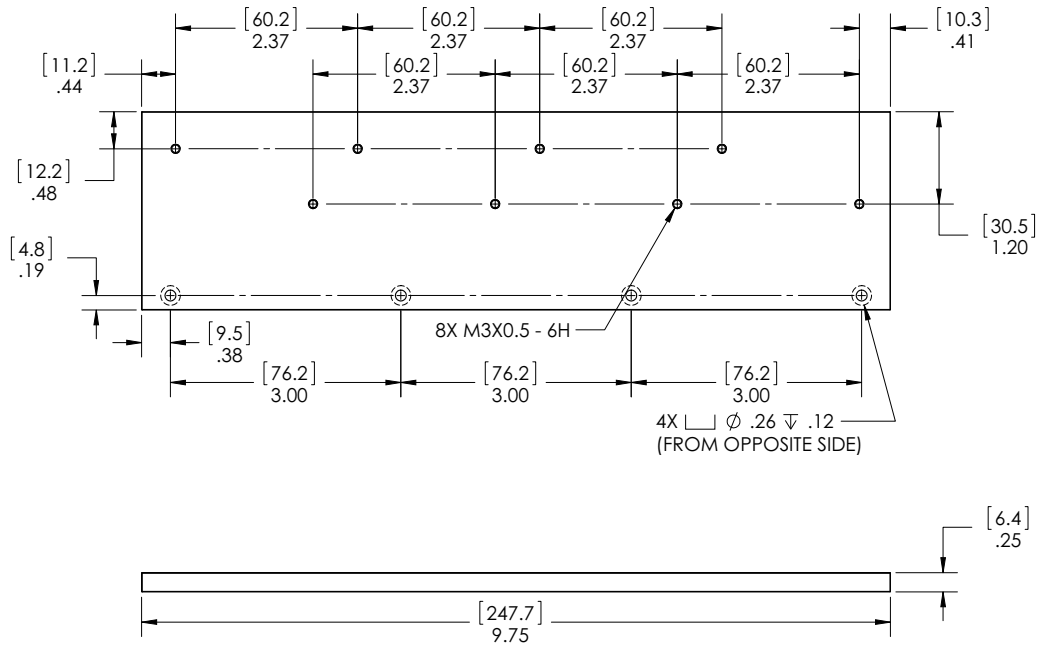

Figure A-12:
Top and Front
Views of Four-
Axis Horizontal
Atlas DK
L-bracket
Vertical Plate

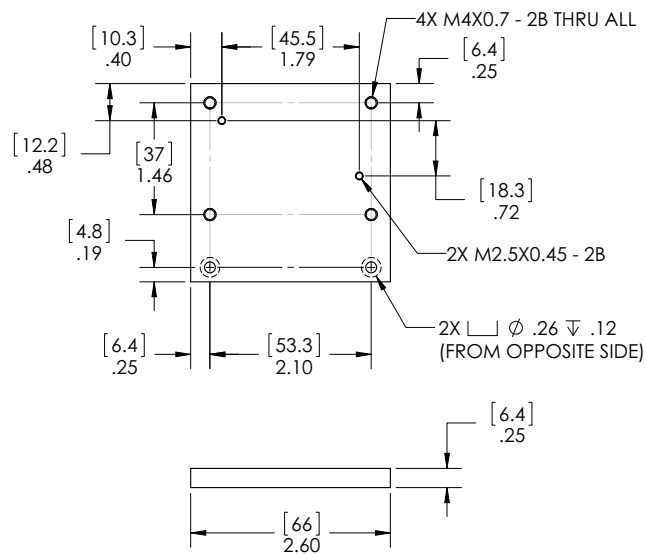

Figure A-13:
Top and Front
Views of One-
Axis Horizontal
Atlas DK
L-bracket
Vertical Plate

This page intentionally left blank.

B. Application Notes

In This Appendix

- ▶ Brushless DC Atlas With Single-Axis MC58113 Motion Control IC
- ▶ DC Brush & Step Motor Atlas With Multi-Axis Magellan
- ▶ Step Motor Atlas Operating In Pulse & Direction Mode
- ▶ DC Brush Atlas With PIC Microcontroller
- ▶ Step Motor Atlas With ARM Microcontroller
- ▶ Atlas Interfacing Via A Daughter Card
- ▶ Multi-Motor Atlas With Single-Axis MC58113 Motion Control IC

B.1 Brushless DC Atlas With Single-Axis MC58113 Motion Control IC

The following schematic shows a Brushless DC Atlas Amplifier connected to a single-axis Magellan.

B.1.1 Atlas Power Input and Motor Output

Atlas is powered through pin pairs HV and Pwr_Gnd, and the power source is a transformer-isolated DC power supply. When unregulated DC power supply is used the output voltage with respect to its output power/current should meet the full Atlas operating range specification. Be aware that for motors operating with significant inertia, during deceleration, Atlas may convert excess kinetic energy to electrical energy and feed the energy back to the DC power supply input. The power supply therefore should be able to absorb or “dump” this regenerated energy so that the increased bus voltage will not trigger an Atlas over-voltage event, or otherwise damage the power supply or other attached devices. An input capacitor can be used to absorb the regenerated energy with $E=C*V*\Delta V$ where E is the kinetic energy, C is the capacitance of the input capacitance, V is the DC bus voltage and ΔV is the allowed voltage increase. For some regulated power sources the regenerated energy may interfere with the power source's operation. If that is the case, you may consider adding a diode between the regulated power source and the input capacitor bank.

The Pwr_Gnd and GND pins are connected together inside the Atlas, and at a system level they refer to the same ground. Pwr_Gnd, the current return path for the power train, is paired with HV and may therefore be noisy. GND is the reference for the SPI signals and other digital control signals. These signals require a quiet ground reference. To ensure optimal performance, star grounding is recommended for component placement and layout. That is, Pwr_Gnd and GND should be connected to the system ground very close to Atlas, and the two ground paths should be kept away from each other.

There is a third current return path stemming from the high frequency component of the motor winding current. Atlas drives motor windings with pulse-width modulated (PWM) signals. Although the sum of the average winding currents is zero, the high frequency PWM signal may couple to the ground plane and induce noise into other circuits. Therefore, depending on your application, you may consider utilizing a shielded motor cable to provide a current return path. If utilized, its ground point should be very close to, or the same, as Pwr_Gnd.

B.1.2 Atlas SPI Interface

Atlas receives control commands through an SPI interface and functions as an SPI slave. Atlas SPI communication is enabled when \sim SPICS is pulled down.

To ensure optimal SPI communication, please consider the following layout recommendations:

- 1 Keep traces short and use 45 degree corners instead of 90 degree corners.
- 2 All SPI signal traces should be located next to a continuous ground plane, or if possible, between two continuous ground planes.
- 3 Keep traces away from other noisy and high speed signal traces. Alternatively, run ground traces along with these signals as a shield.
- 4 When multiple Atlas modules are used, keep the SPI signal stubs short.

Note that the Atlas Development Kit layout can be used as a layout reference.

B.1.3 Atlas ~Enable and FaultOut Signals

Atlas has one dedicated input signal, ~Enable, which must be pulled low for the Atlas output stage to be active.

FaultOut is a dedicated output. During normal operation it outputs low. When a fault occurs it will go into a high impedance state. In this example, FaultOut is pulled up by Vpullup through resistor R1. Vpullup can be up to 24V to meet the system requirement. For example, if the fault signal is wired to a 5V TTL input, Vpullup can be 5V.

B.1.4 Magellan MC58113 Configuration

In this schematic the SPI master is a single axis Magellan MC58113. Only the connections with Atlas are shown. For complete MC58113 wiring, please refer to the MC58113 electrical specifications. Depending on the Magellan commutation method selected the feedback signals HallA, HallB, HallC and ~Index are optional.

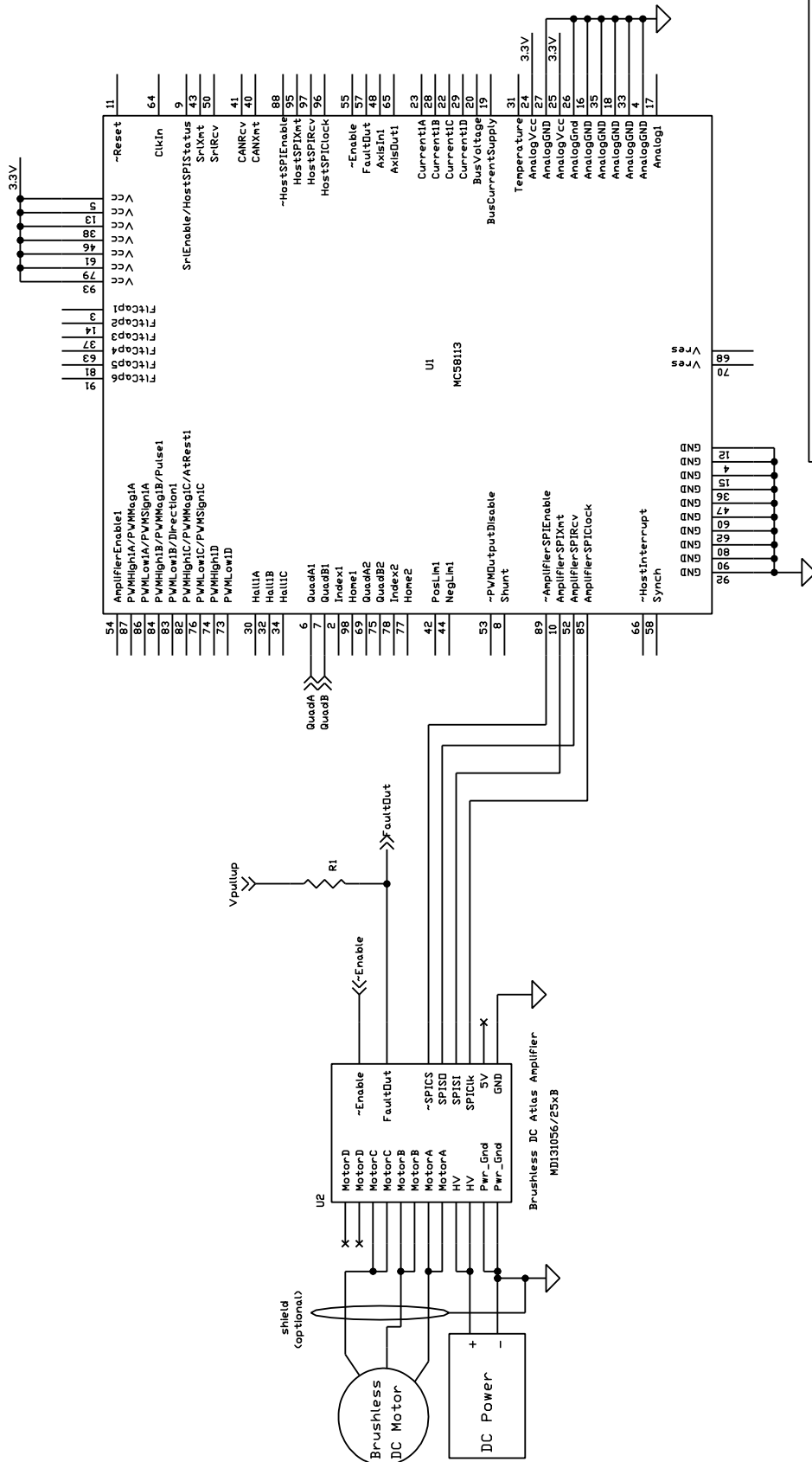

Performance Motion Devices, Inc.	
Title	Brushless DC Atlas With MCS58113
Size	B
Document Number	
Rev	A
Date	Sheet 1 of 1

Figure B-1: Brushless DC Atlas With Single-Axis Magellan

B.2 DC Brush & Step Motor Atlas With Multi-Axis Magellan

The following schematic shows a two-axis application with one DC Brush Atlas Amplifier and one step motor Atlas amplifier controlled by a multi-axis Magellan.

B.2.1 Atlas Power Input and Motor Output

Atlas is powered through pin pairs HV and Pwr_Gnd, and the power source is a transformer-isolated DC power supply. In this application the two Atlases share the same power supply. Alternatively they could be powered independently so that different motor voltages could be used.

For DC Brush motors pins MotorA and MotorB are wired to motor windings Motor+ and Motor-, respectively. Pins MotorC and MotorD are left un-connected.

For step motors pins MotorA, MotorB, MotorC and MotorD are wired to motor windings A+, A-, B+ and B-, respectively.

Please refer to B.1 for layout and wiring recommendations on power input and motor outputs.

B.2.2 Atlas SPI Interface

Atlas receives control commands through an SPI interface and functions as an SPI slave. Atlas SPI communication is enabled when \sim SPICS is pulled down. Only one Atlas can be enabled at any given time.

Please refer to B.1 for layout recommendation on SPI interface.

B.2.3 Atlas \sim Enable and FaultOut Signals

Atlas has one dedicated input signal, \sim Enable, which must be pulled low for the Atlas output stage to be active.

FaultOut is a dedicated output. During normal operation it outputs low. When a fault occurs it will go into a high impedance state. In this example, FaultOut is pulled up by Vpullup through resistor R1. Vpullup can be up to 24V to meet the system requirement. Each Atlas may use a different Vpullup voltage, for example, if the fault signal is wired to a 5V TTL input, Vpullup can be 5V.

B.2.4 Magellan MC58420 Configuration

In this schematic the SPI master is a four-axis Magellan MC58420. Only the connections with Atlas are shown. For complete Magellan wiring, please refer to the MC58420 electrical specifications.

The MC58420 is configured to default to Atlas motor output by tying pin 7, OutputMode0, to ground. In this example axis 2 and axis 3 are under control. The MC58420 sends torque commands to the DC Brush Atlas by pulling SPIEnable2 low, and sends position commands to the step motor Atlas by pulling SPIEnable3 low.

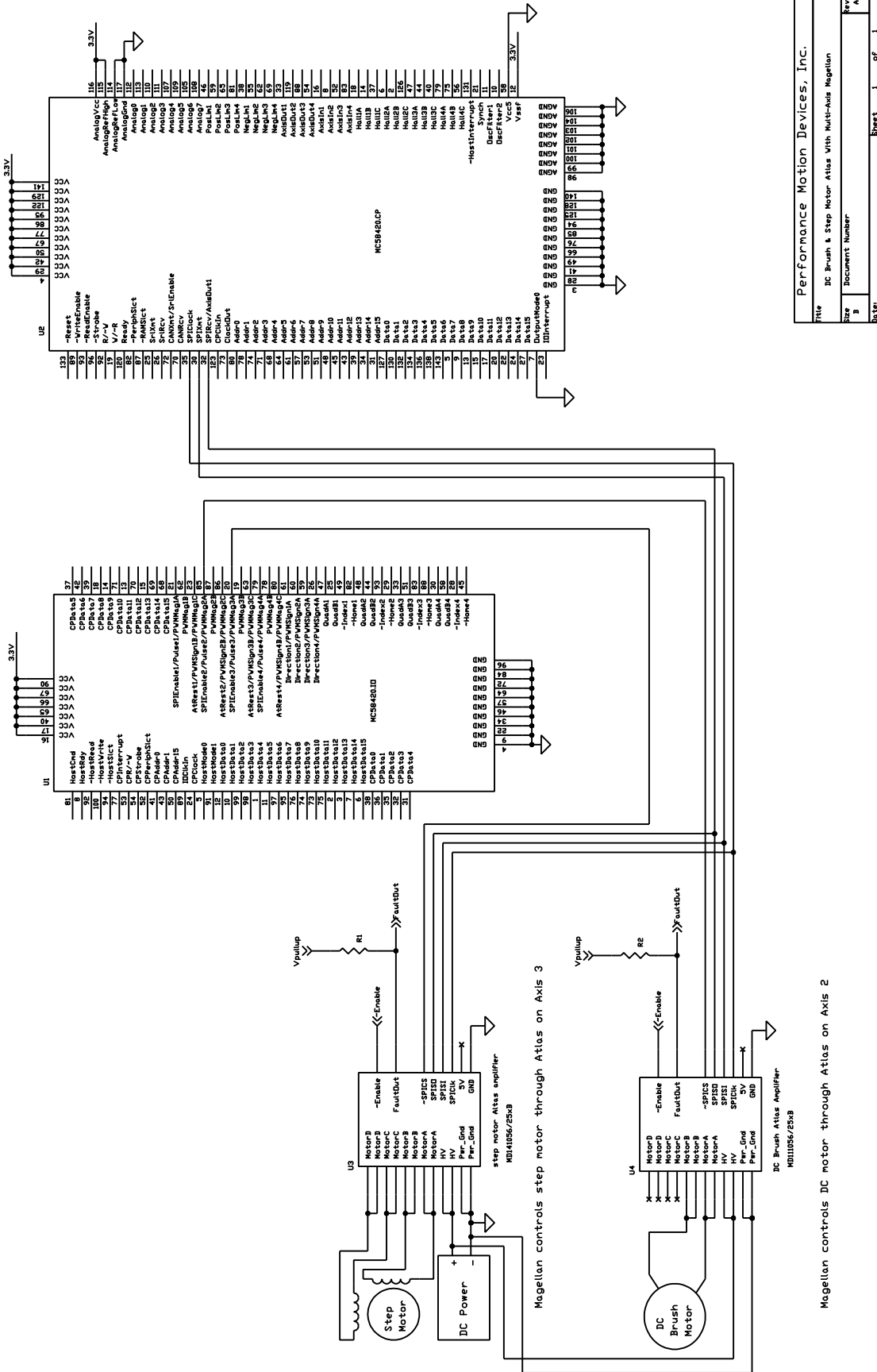

Figure B-2: DC Brush & Step Motor Atlas With Multi-Axis Magellan

B.3 Step Motor Atlas Operating In Pulse & Direction Mode

The following schematic shows Atlas operated in pulse & direction mode controlled by a single axis Magellan. Note that any source of pulse & direction signals, such as a microprocessor or other dedicated motion control IC, may be substituted for the Magellan in this schematic.

B.3.1 Atlas Power Input and Motor Outputs

Atlas is powered through pin pairs HV and Pwr_Gnd, and the power source is a transformer-isolated DC power supply.

For step motors pins MotorA, MotorB, MotorC and MotorD are wired to motor windings A+, A-, B+ and B-, respectively.

Please refer to B.1 for layout and wiring recommendations on power input and motor outputs.

B.3.2 Atlas Pulse & Direction Interface

When in pulse & direction signal mode, Atlas receives pulse, direction and AtRest signals as shown in the schematic. When operated in pulse & direction signal mode SPI communications are not available.

B.3.3 Atlas ~Enable and FaultOut Signals

Atlas has one dedicated input signal, ~Enable, which must be pulled low for the Atlas output stage to be active.

FaultOut is a dedicated output. During normal operation it outputs low. When a fault occurs it will go into a high impedance state. In this example, FaultOut is pulled up by Vpullup through resistor R1. Vpullup can be up to 24V to meet the system requirement. For example, if the fault signal is wired to a 5V TTL input, Vpullup can be 5V.

B.3.4 Magellan MC54113 Configuration

In this schematic the SPI master is a single-axis Magellan MC54113 configured for pulse & direction signal output. Only the connections with Atlas are shown. For complete Magellan wiring, please refer to the MC58113 electrical specifications.

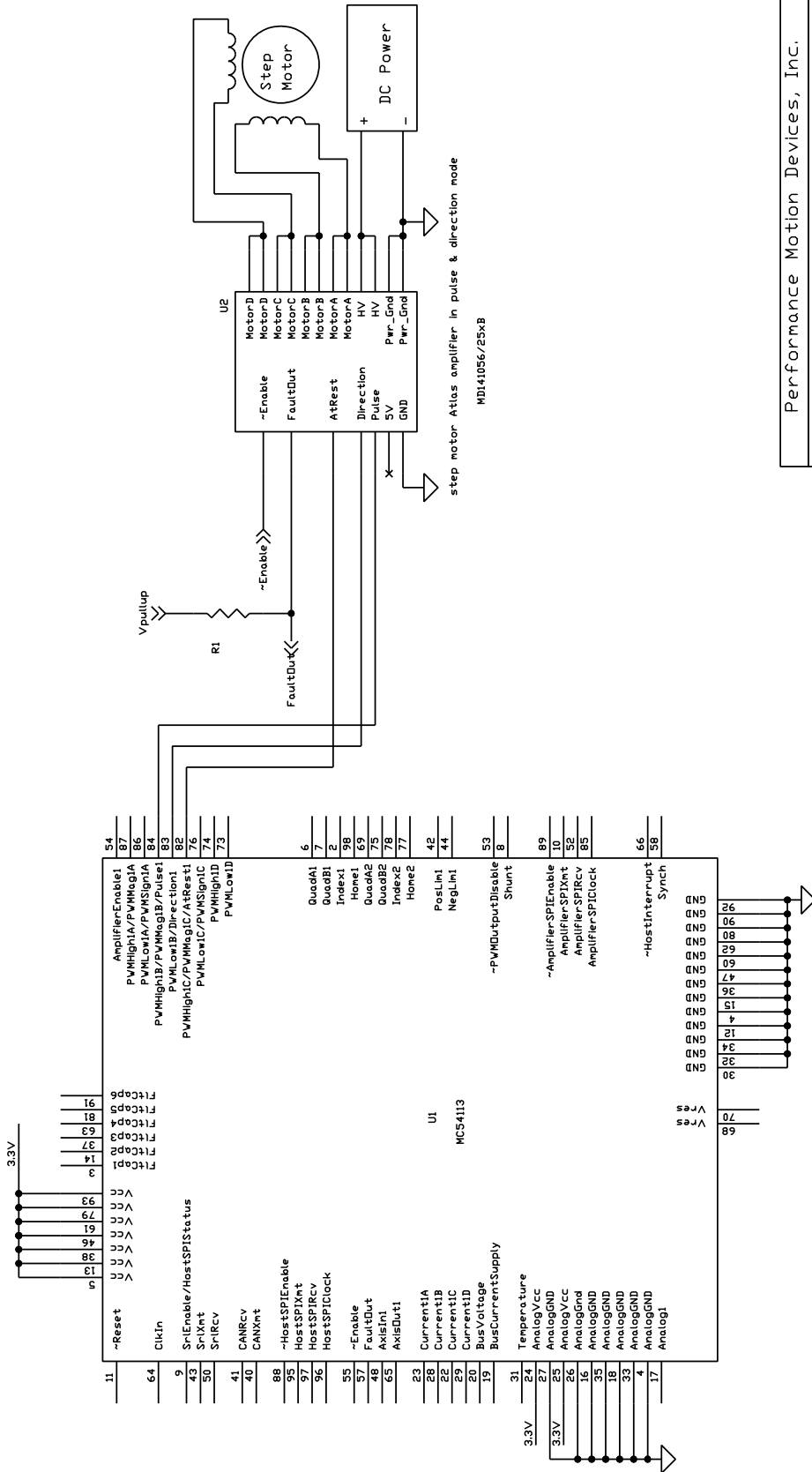

Performance Motion Devices, Inc.	
Title	Step Motor Atlas Operating in Pulse & Direction Mode
Size	Document Number
Rev	Rev A
Date	Sheet 1 of 1

Figure B-3:
Step Motor
Atlas Operating
In Pulse &
Direction Mode

B.4 DC Brush Atlas With PIC Microcontroller

The following schematic shows a DC Brush Atlas amplifier connected to a Microchip Technologies' PIC microcontroller. Atlas receives torque commands through the PIC's SPI interface.

A wide variety of microcontrollers, DSP-type devices, or FPGAs supporting SPI interfaces can control Atlas directly. Microchip's dsPIC33FJ64GS606 is used in this example. It supports encoder inputs and other feedback inputs. Users design their own motion control algorithms on the microcontroller, which in turn commands Atlas to drive the motor.

B.4.1 Atlas Power Input and Motor Output

Atlas is powered through pin pairs HV and Pwr_Gnd, and the power source is a transformer-isolated DC power supply.

For DC Brush motors pins MotorA and MotorB are wired to motor windings Motor+ and Motor-, respectively. Pins MotorC and MotorD are left un-connected.

Please refer to B.1 for layout and wiring recommendation on power input and motor outputs.

B.4.2 Atlas SPI Interface

Atlas functions as an SPI slave, receiving control commands from the PIC through its SPI interface. Atlas SPI communication is enabled when \sim SPICS is pulled down.

Please refer to B.1 for layout recommendation on SPI interface.

B.4.3 Atlas \sim Enable and FaultOut Signals

Atlas has one dedicated input signal, \sim Enable, which must be pulled low for the Atlas output stage to be active.

FaultOut is a dedicated output. During normal operation it outputs low. When a fault occurs it will go into a high impedance state. In this example, FaultOut is pulled up by Vpullup through resistor R1. Vpullup can be up to 24V to meet the system requirement. For example, if the fault signal is wired to a 5V TTL input, Vpullup can be 5V.

B.4.4 Microcontroller Configuration

In this schematic, the host controller is Microchip's dsPIC33FJ64GS606. The microcontroller's SPI port (SDI1/SDO1/SCK1) is used for SPI communication.

In this example output pin #12 of U1 (PIC processor) is used to control Atlas' \sim SPICS input. \sim SPICS has an internal pull-up, therefore, during power up and after reset, the control pin should be in high-impedance or output high state to disable the SPI. Resistor R2 is optional.

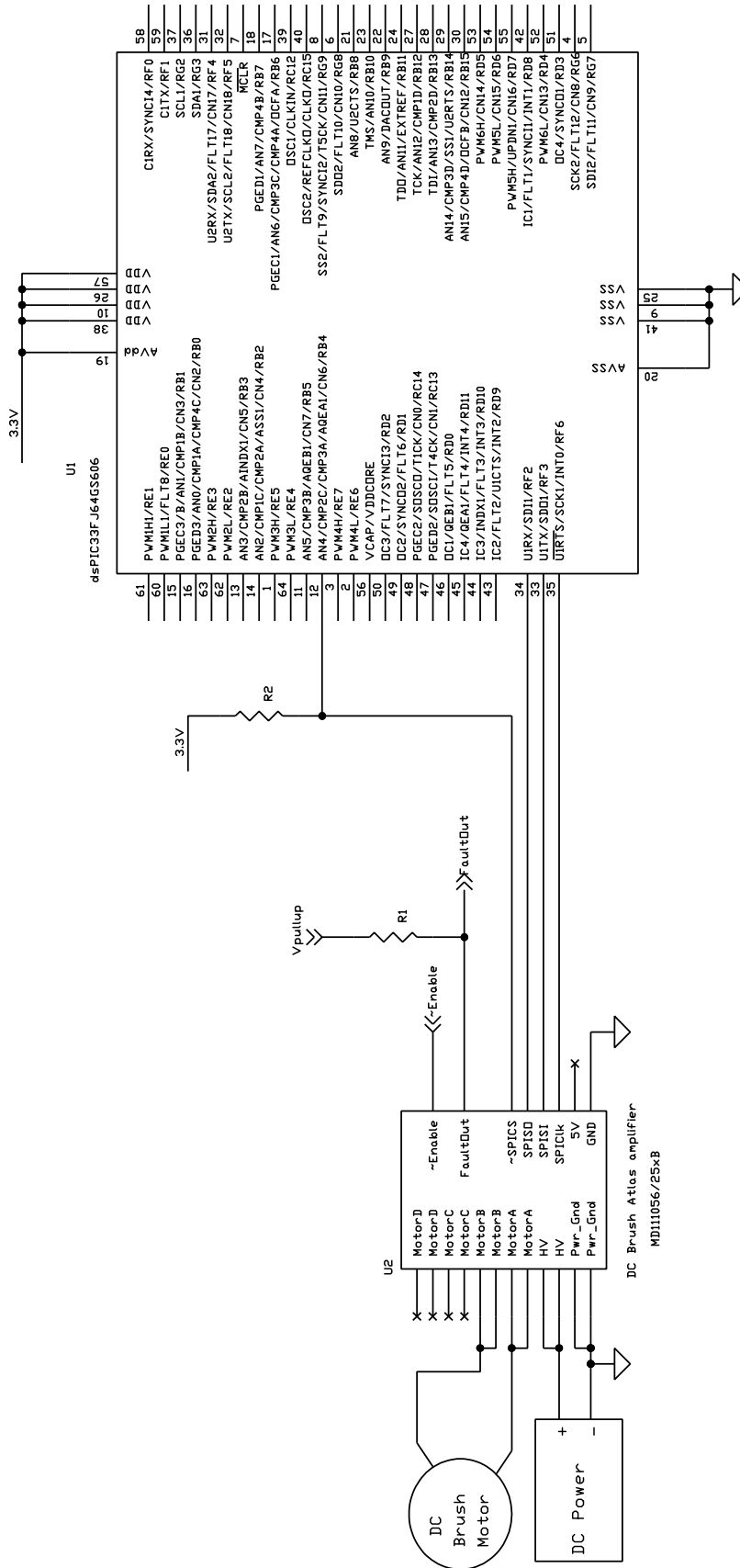

Title		DC Brush Atlas With PIC Microcontroller	
Size	Document Number	Rev	A
Date:		Sheet	1 of 1

Figure B-4:
DC Brush Atlas
With PIC
Microcontroller

B.5 Step Motor Atlas With ARM Microcontroller

The following schematic shows a step motor Atlas amplifier connected to an STMicroelectronic's ARM microcontroller. Atlas receives torque commands through the ARM's SPI interface.

A wide variety of microcontrollers, DSP-type devices, or FPGAs supporting SPI interfaces can control Atlas directly. STMicroelectronic's STR912FAZ44H6T is used in this example. Users design their own motion control algorithms on the microcontroller, which in turn commands Atlas to drive the motor.

B.5.1 Atlas Power Input and Motor Outputs

Atlas is powered through pin pairs HV and Pwr_Gnd, and the power source is a transformer-isolated DC power supply.

For step motors pins MotorA, MotorB, MotorC and MotorD are wired to motor windings A+, A-, B+ and B-, respectively.

Please refer to B.1 for layout and wiring recommendations on power input and motor outputs.

B.5.2 Atlas SPI Interface

Atlas functions as an SPI slave, receiving control commands from the ARM through its SPI interface. Atlas SPI communication is enabled when \sim SPICS is pulled down.

Please refer to B.1 for layout recommendation on SPI interface.

B.5.3 Atlas \sim Enable and FaultOut Signals

Atlas has one dedicated input signal, \sim Enable, which must be pulled low for the Atlas output stage to be active.

FaultOut is a dedicated output. During normal operation it outputs low. When a fault occurs it will go into a high impedance state. In this example, FaultOut is pulled up by Vpullup through resistor R1. Vpullup can be up to 24V to meet the system requirement. For example, if the fault signal is wired to a 5V TTL input, Vpullup can be 5V.

B.5.4 Microcontroller Configuration

In this schematic, the host controller is ST's STR912FAZ44H6T. The microcontroller's SPI port is used for SPI communication.

In this example output pin K7 of the U1 (ARM processor) is used to control Atlas' \sim SPICS input. \sim SPICS has an internal pull-up, therefore, during power up and after reset, the control pin should be in high-impedance or output high state to disable the SPI.

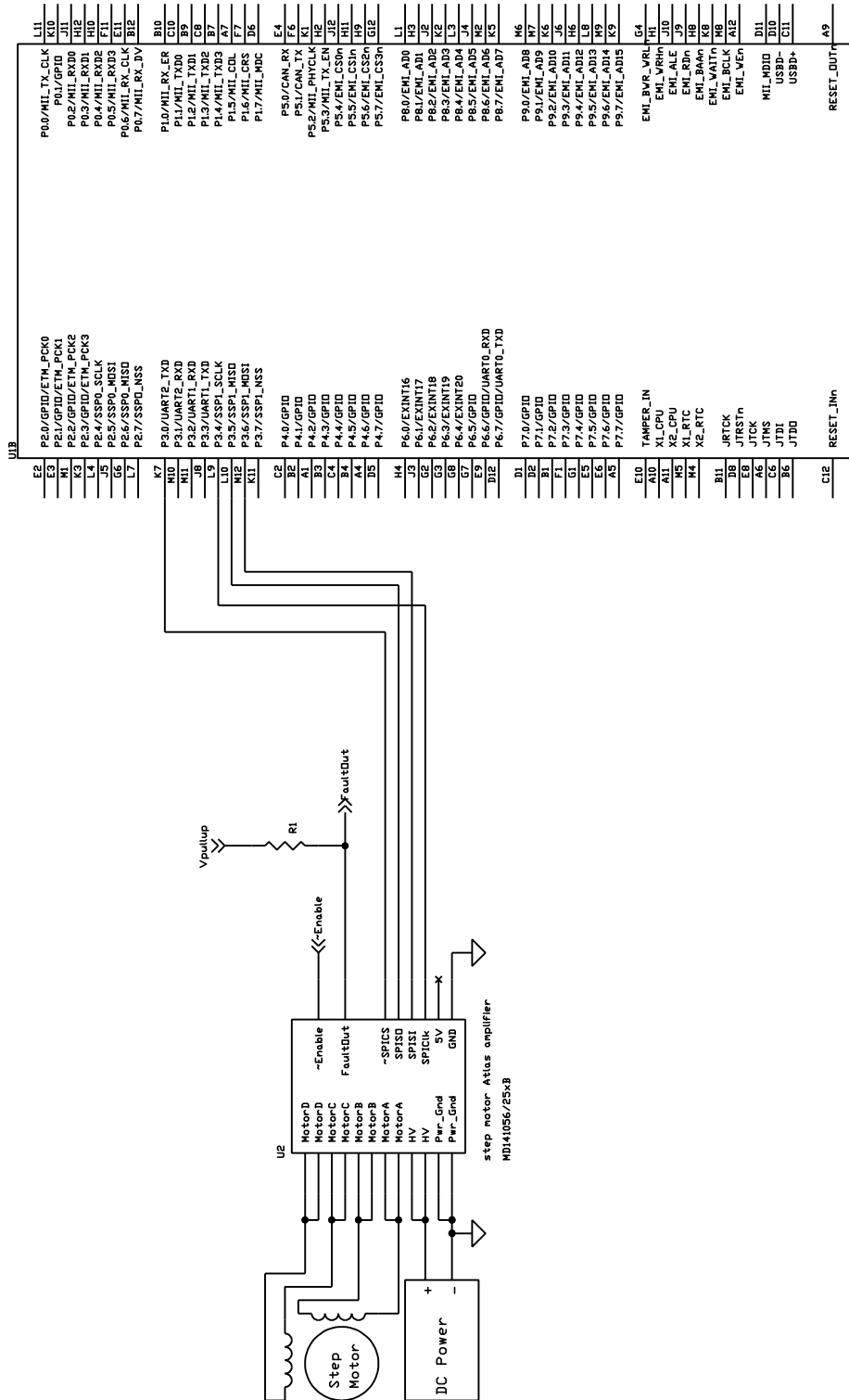

Performance Motion Devices, Inc.

Title		Step Motor Atlas With ARM Microcontroller
Size	B	Document Number
Rev	A	
Sheet		1 of 1

Figure B-5: Step Motor Atlas With ARM Microcontroller

B.6 Atlas Interfacing Via A Daughter Card

The following schematic shows an example of Atlas interfacing via a daughter card.

B.6.1 Atlas Application Considerations Via a Daughter Card

Ground placement is critical for Atlas operation. Atlas is powered through pin pairs HV and Pwr_Gnd with a transformer-isolated DC power supply. The Pwr_Gnd and GND pins are shorted inside the Atlas, and at a system level they refer to the same ground. Pwr_Gnd is the current return path for the power train, while GND is the reference for the SPI signals and other digital control signals. Also, there is another current return path from the high frequency component of the motor winding current. To ensure optimal performance, star grounding is recommended for component placement and layout. That is, Pwr_Gnd and GND should be connected to the system ground very close to Atlas, and the ground return paths should be kept away from each other. Please refer to B.1 for general layout and wiring considerations on power input and motor outputs.

When Atlas is used with a daughter card, above grounding requirements might be difficult to implement at system level. For example, Atlas is installed close to the motor on a daughter card while the host controller resides in the mother board. The host controller controls Atlas through a cable, and too long a cable might compromise the module performance. Another example is that a single power supply powers multiple Atlas daughter card at different locations through long, separate, power cables. The long cables establish a current loop, and the ground current might interfere with normal Atlas operation.

This application note provides some examples to address above issues. In the example schematic, PMD's Magellan IO and CP chips are used to control the two Atlas units on the daughter card(s). Because of the length of the connecting cable between the host board and daughter board(s), there are buffers added on the SPI bus on the host board in order to boost the signal driving and sinking capabilities.

B.6.2 Atlas SPI Through Isolator

Atlas receives control commands through an SPI interface and functions as an SPI slave; The SPI signals refer to its "local" ground. However, when Atlas is on a daughter card with a cable to the host controller, the host controller's local ground might be different, and SPI communication might see errors due to the ground difference/noise.

An isolator can be used to "break" the ground so that Atlas and the host controller refer to their own grounds. In this example, U1 and U2 are digital isolators. Atlas refers to "side B" ground and the host controller to "side A" ground. Please note that the isolators have to meet the timing specification for Atlas communication because the isolator will add delay to the signals. The buffer U5 and U6 are to boost the signal driving and sinking capability after the isolator output. In this example, DB9 connector with shielded DB9 cable is used. When R3 is zero, the shield is connected to side A ground at the daughter card end. Similarly, on the Magellan side (on the mother board), buffer U7 and U9 are used to boost the signal driving and sinking capability, and, when R4 is zero, the shield is connected to side A ground at the host end. Depending on the design layout, a Schmitt trigger input or standard termination practice might be necessary for the application with long cables.

B.6.3 HV and Pwr_Gnd High-Frequency Isolation

When a single power supply powers multiple Atlas modules through long, separate, power cables, the long cables establish a current loop because they are shorted at both the power supply and the Atlas end. It will result in ground currents that might interfere with normal Atlas operation.

In this case, an L-C-L network can be used to provide high-frequency isolations among the modules. For example, for Atlas U3, C1 is between the Atlas HV and Pwr_Gnd. It serves as the bank capacitor for Atlas operation when necessary. L1 is between Atlas HV and power supply positive output. L2 is between Atlas Pwr_Gnd and power supply ground return. The current rating of L1 and L2 has to fit the Atlas operation current. L1 and L2 will bring in high impedance at high frequency to attenuate the ground current. A separated L-C-L network is used for Atlas U4 for optimum performance.

**Figure B-6:
Atlas
Interfacing Via
A Daughter
Card #1**

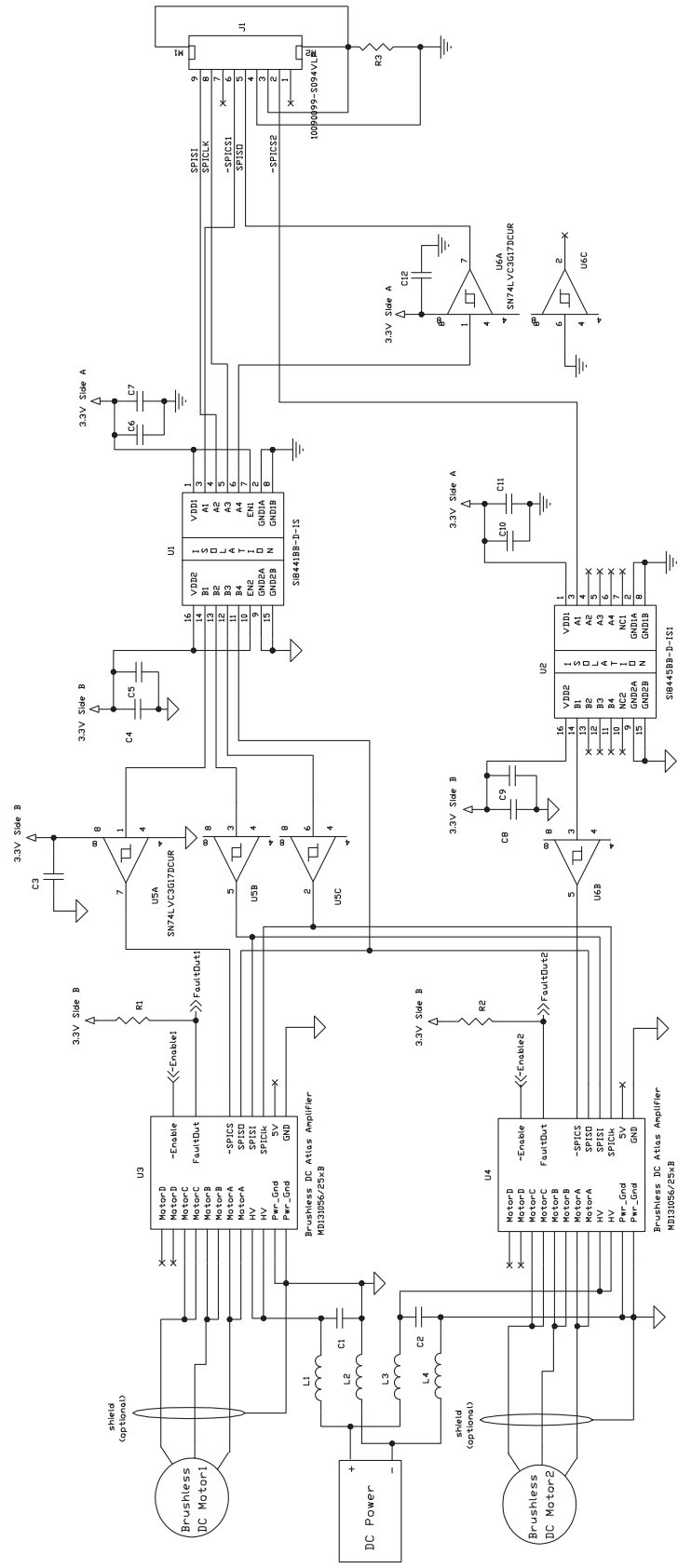

Title		Performance Motion Devices, Inc.	
Size		Atlas Interfacing via a Daughtercard - Page 1	
Doc Number	Rev	Document Number	Rev
B	A		A
Date:	Sheet	1	of 1

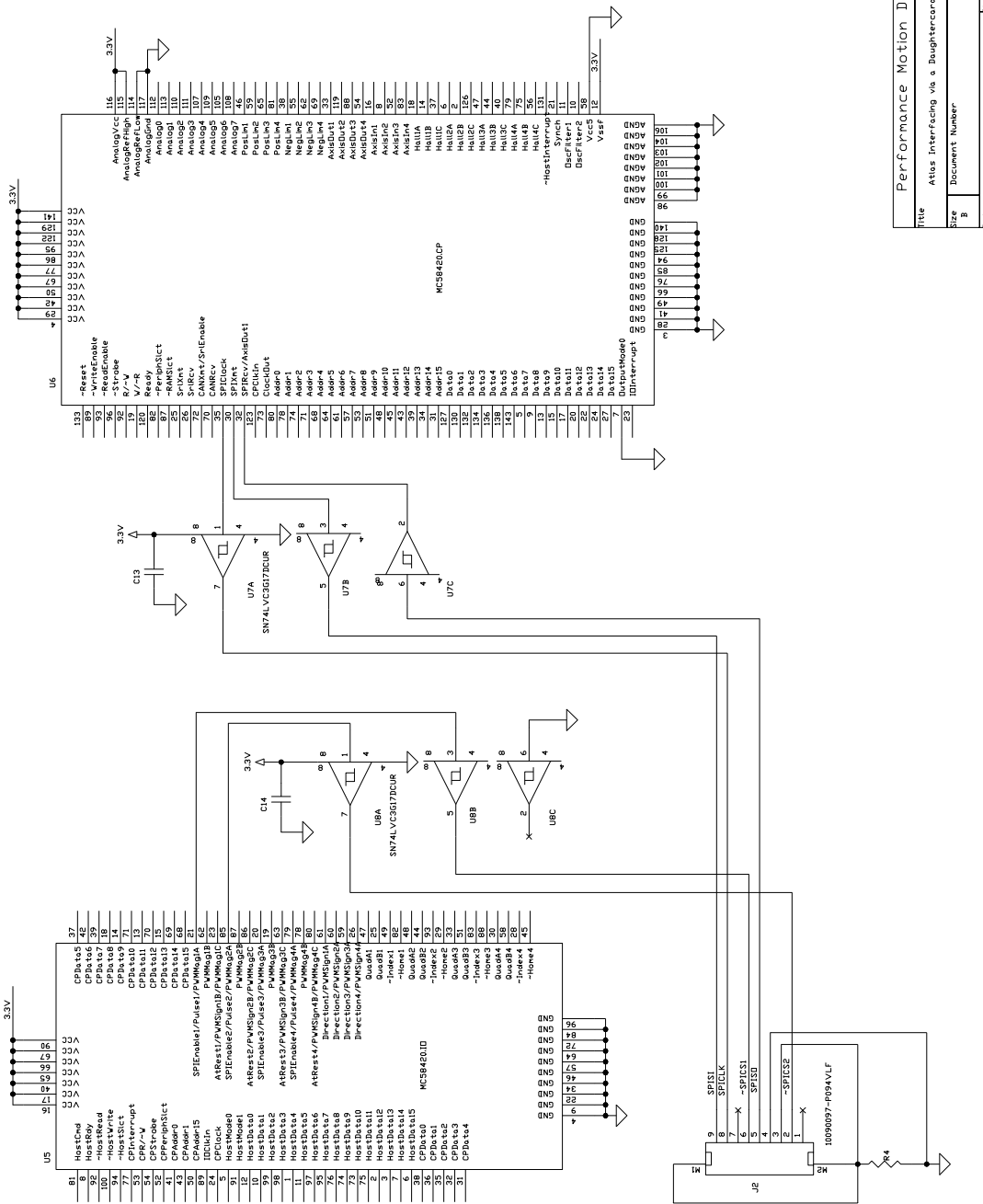

Performance Motion Devices, Inc.

Title	Atlas Interfacing via a Daughtercard - Page 2
Size	B
Document Number	Rev A
Date	Sheet 1 of 1

Figure B-7: Atlas Interfacing Via A Daughter Card #2

B.7 Multi-Motor Atlas With Single-Axis MC58113 Motion Control IC

The following schematic shows multi-motor Atlas with single-axis MC58113 motion control IC.

B.7.1 Atlas Power Input and Motor Outputs

Atlas is powered through pin pairs HV and Pwr_Gnd, and the power source is a transformer-isolated DC power supply.

Multi-motor Atlas can be configured to support DC brush motor, Brushless DC motor or step motor. For DC Brush motors pins MotorA and MotorB are wired to motor windings Motor+ and Motor-, respectively. Pins MotorC and MotorD are left un-connected. For Brushless DC motors pin Motor A, MotorB and MotorC are wired to motor windings A, B and C, respectively. Pin MotorD is left un-connected. For step motors pins MotorA, MotorB, MotorC and MotorD are wired to motor windings A+, A-, B+ and B-, respectively.

Please refer to [Section B.1, "Brushless DC Atlas With Single-Axis MC58113 Motion Control IC,"](#) for layout and wiring recommendations on power input and motor outputs.

B.7.2 Atlas SPI Interface

Atlas receives control commands through an SPI interface and functions as an SPI slave. Atlas SPI communication is enabled when \sim SPICS is pulled down. Only one Atlas can be enabled at any given time. Please refer to [Section B.1, "Brushless DC Atlas With Single-Axis MC58113 Motion Control IC,"](#) for layout recommendation on SPI interface.

B.7.3 Atlas \sim Enable and FaultOut Signals

Atlas has one dedicated input signal, \sim Enable, which must be pulled low for the Atlas output stage to be active. FaultOut is a dedicated output. During normal operation it outputs low. When a fault occurs it will go into a high impedance state. In this example, FaultOut is pulled up by Vpullup through resistor R1. Vpullup can be up to 24V to meet the system requirement. For example, if the fault signal is wired to a 5V TTL input, Vpullup can be 5V.

B.7.4 Magellan MC58113 Configuration

In this schematic the SPI master is a single-axis MC58113. Only the connections with Atlas are shown. For complete Magellan wiring, please refer to the MC58113 electrical specifications.

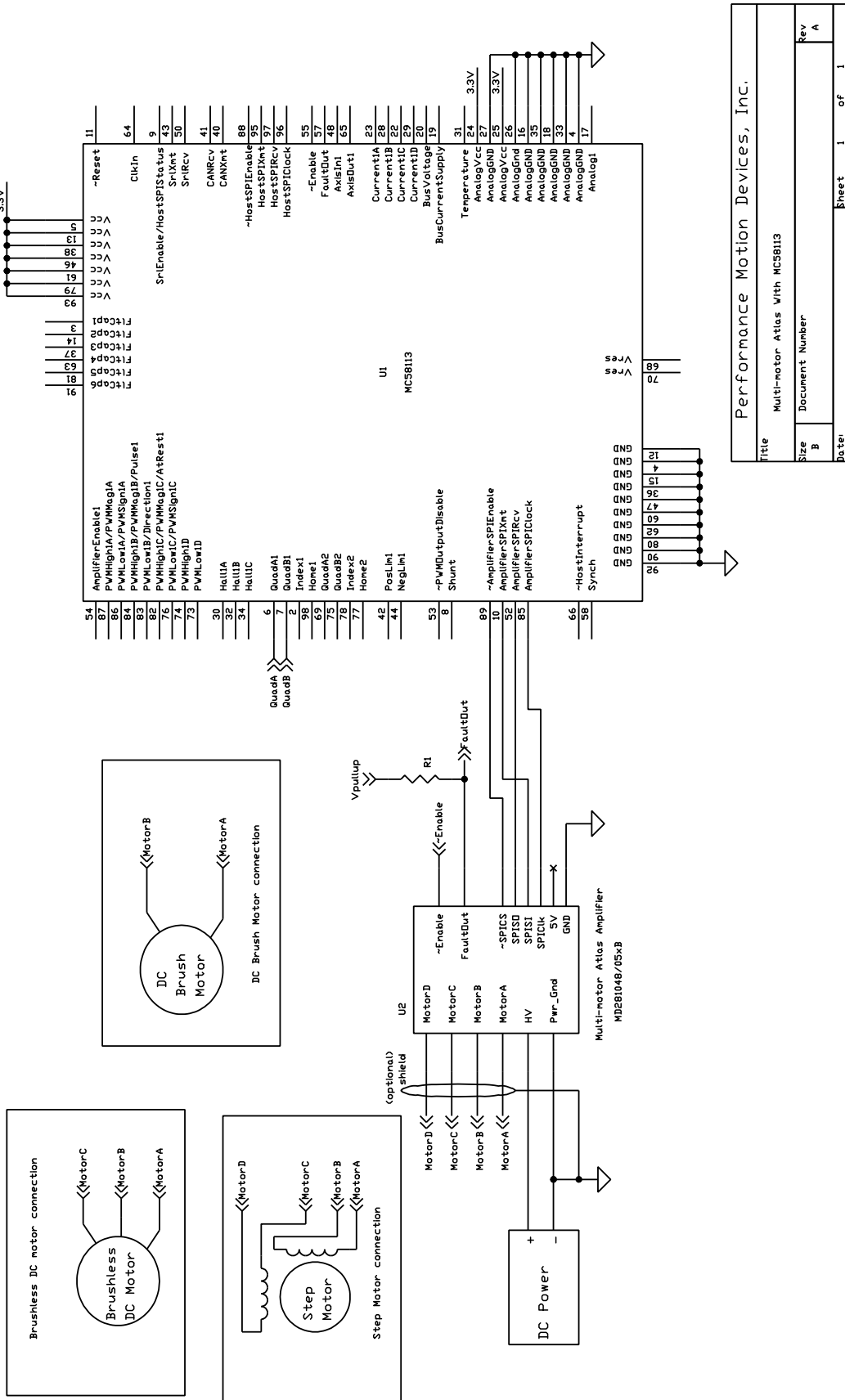

Performance Motion Devices, Inc.	
Title	Multi-motor Atlas With MC58113
Size	Document Number
Rev	A
Date:	Sheet 1 of 1

Figure B-8:
Multi-motor
Atlas With
MC58113
Motion Control
IC

This page intentionally left blank.

Index

Symbols

~Enable 28

~SPICS 28

A

absolute maximum ratings 26

AC characteristics 29

application notes 71

Atlas amplifier

electrical installation 57

Atlas Developer's Kit 14, 55

getting started 56

installation 56

overview 55

B

brushless DC Atlas, single-axis magellan 71

brushless DC motors 35

buffers 51

C

commutation 43

compliance 27

connecting, to the Magellan DK Card 61

connection

brushless DC motors 35

DC brush motors 36

overview 35

power 61

connections 65

motor 61

current control, step motors 51

current foldback 48

current loop 44

D

DC brush & step motor Atlas, multi-axis magellan 74

DC brush Atlas, PIC microcontroller 78

DC brush motors 36

DC characteristics 27

~Enable 28

~SPICS 28

5V 28

FaultOut 28

SPIClk 27

SPISI 27

SPISO 27

DK board reference information 62

drive

fault status register 48

ratings 25

E

electrical specifications 25

Enable signal connection 61

environmental ratings 27

F

fault

overcurrent 46

overtemperature 46

FaultOut 28

FaultOut Signal 48

features 12

functional overview 41

functions 12

H

horizontal unit

with tabs 19

without tabs 19

I

internal block diagram 42

J

J1 & J2 jack screw connectors 63

J4 connectors 64

J5 DB9 connectors 64

L

L-bracket 68

LED indicators 67

M

Magellan DK Card, connecting to 61

motor

- connection 61
- current, setting 50

mounting

- dimensions 18
- options 20

N

non-volatile initialization storage 52

O

operation 41

operational specifications 17

overcurrent fault 46

overtemperature fault 46

overview 9

overvoltage fault 47

P

physical characteristics 18

pin descriptions 29, 32

pinouts 29

- Atlas horizontal unit 30
- Atlas vertical unit 30

power

- connections 61
- stage 45

powering up, Atlas units 62

power-up 52

pulse & direction signal input mode 50

R

ratings

- absolute maximum 26
- drive 25
- environmental 27

S

safety 27

safety processing functions 46

current foldback 48

drive

- fault status register 48

drive enable

- drive enable 48

FaultOut Signal 48

overcurrent fault 46

overtemperature fault 46

overvoltage fault 47

undervoltage fault 47

watchdog timeout 47

set

motor current 50

signal interfacing 34

~Enable 34

FaultOut 34

SPI bus connections 60

SPI communications overview 52

SPIClk 27

SPISI 27

SPISO 27

status registers 45

step motor Atlas, ARM microcontroller 80

step motor Atlas, pulse & direction mode 76

step motor control 49

step motors

- pulse & direction signal mode 37

SPI communications 38

T

trace

- capture 51

U

undervoltage fault 47

user memory space 51

V

vertical unit

- with tabs 18
- without tabs 18

voltage or torque output 53

W

watchdog timeout 47